



Europäisches Patentamt
European Patent Office
Office européen des brevets



FJ

Publication number: **0 663 313 A1**

EUROPEAN PATENT APPLICATION

Application number: 95104980.8

Int. Cl.⁶: **B60L 7/10, B60L 3/00**

Date of filing: 07.04.92

This application was filed on 03 - 04 - 1995 as a divisional application to the application mentioned under INID code 60.

Priority: 09.04.91 JP 103324/91
21.10.91 JP 299562/91
11.04.91 JP 105098/91

Date of publication of application: 19.07.95 Bulletin 95/29

Publication number of the earlier application in accordance with Art.76 EPC: 0 508 367

Designated Contracting States: DE FR GB IT

Applicant: HONDA GIKEN KOGYO KABUSHIKI KAISHA
1-1, Minamiaoyama 2-chome
Minato-ku
Tokyo (JP)

Inventor: Toriyama, Masayuki, c/o KK Honda Gijutsu Kenkyusho
4-1, Chuo 1-chome
Wako-shi,
Saitama (JP)
Inventor: Tamaki, Kenji, c/o K.K. Honda Gijutsu Kenkyusho
4-1, Chuo 1-chome
Wako-shi,
Saitama (JP)
Inventor: Honda, Satoshi, c/o K.K. Honda Gijutsu Kenkyusho

4-1, Chuo 1-chome
Wako-shi,
Saitama (JP)
Inventor: Motodate, Shoji, c/o K.K. Honda Gijutsu Kenkyusho
4-1, Chuo 1-chome
Wako-shi,
Saitama (JP)
Inventor: Nakazawa, Yoshihiro, c/o KK Honda Gijutsu Kenkyusho
4-1, Chuo 1-chome
Wako-shi,
Saitama (JP)
Inventor: Fujii, Takaaki, c/o K.K. Honda Gijutsu Kenkyusho
4-1, Chuo 1-chome
Wako-shi,
Saitama (JP)
Inventor: Sasaki, Shigeml, c/o K.K. Honda Gijutsu Kenkyusho
4-1, Chuo 1-chome
Wako-shi,
Saitama (JP)

Representative: Fincke, Karl Theodor, Dipl.-Phys. Dr. et al
Patentanwälte
H. Weickmann, Dr. K. Fincke
F.A. Weickmann, B. Huber
Dr. H. Liska, Dr. J. Prechtel, Dr. B. Böhm,
Kopernikusstrasse 9
D-81679 München (DE)

A braking control system for an electric vehicle.

A controller for an electric vehicle driven by an electric motor the speed of which is controlled according to a voltage comprising:
monitor means for monitoring functions of the electric vehicle to detect a malfunction therein; and
correcting means for generating a corrected voltage

by gradually decreasing the voltage for controlling speed when the malfunction is detected by said monitor means
said correcting means supplying said corrected voltage to the electric motor (M) when the malfunction is detected.

EP 0 663 313 A1

Fig. 22

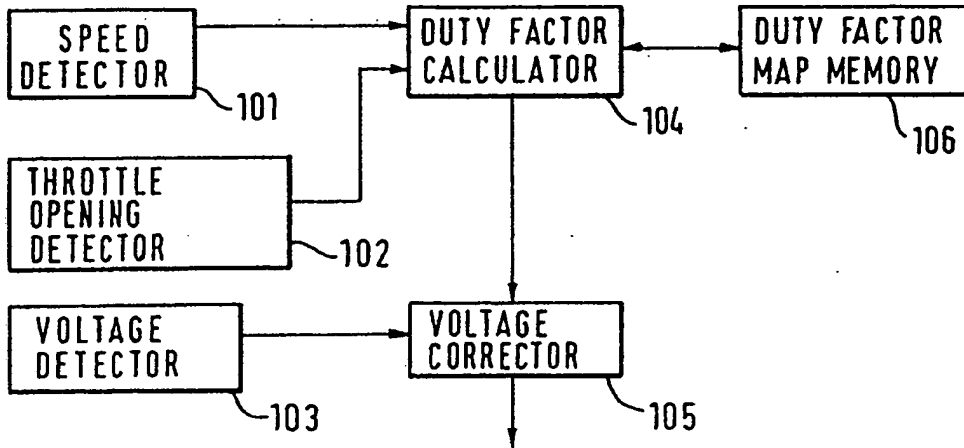

BACKGROUND OF THE PRESENT INVENTION

The present invention relates to a regenerative braking control system for an electric vehicle driven by an electric power supply, namely a battery. More specifically, the present invention relates to a regenerative braking control system for electric vehicle which is capable of individually controlling the charging current for recharging the battery and the braking force applied by the brakes.

The present invention also relates to a controller for an electric vehicle driven by an electric motor. More specifically, the present invention relates to a controller for an electric vehicle which is capable of securing satisfactory controllability even if a portion of the electric system for controlling the driving of the drive motor malfunctions during a running operation.

Regenerative braking is used widely as an energy saving means for an electric vehicle employing a DC motor as its driving force. Regenerative braking is achieved by interrupting the power supply to the DC motor, converting the kinetic energy of the DC motor into electric energy, and utilizing this electric energy to recharge the power supply.

Figure 5 is a block diagram illustrating a portion of the motor control system for an electric vehicle. Figure 6 is a timing diagram which illustrates the procedure for controlling the regenerative braking process.

Referring to Figure 5, driving coils U, V, and W are wound on a stator 37, and a rotor shaft 19 is mounted with a rotor 51 and a magnet rotor 48 for rotation within the central portion of the stator 37. Hall-effect devices UH, VH, and WH are arranged around the magnet rotor 48 for determining, in a non-contactual manner, the angular position of the rotor 51. Detection signals produced by the Hall-effect devices are fed to an angular position detecting device 46. The angular position detecting device 46 determines the angular position of the rotor 51 based on the detection signals and produces an angular position signal which is fed to a commutation/rectification control device 45.

The commutation/rectification control device 45 includes a running mode commutation control device 45a which operates during the normal running state, a regenerative mode rectification control device 45b which operates during a regenerative state, and a switching circuit 45c for selecting either the running mode commutation control device 45a or the regenerative mode rectification control device 45b.

The driving coils U, V, and W are connected to a commutating/rectifying device 90. This commutating/rectifying device 90 includes a switching unit 90a which includes transistors and diodes in combination and a pre-driving unit 90b. The switching

unit 90a controls the power supplied from a battery BA to the driving coils U, V, and W. This switching unit 90a also acts as a path for feeding the recharging power from the driving coils to the battery BA.

During a normal running state, the switching circuit 45c selects the running mode commutation control device 45a so that the commutation/rectification control device 45 operates properly during the running mode.

The running mode commutation control device 45a switches the transistors of the switching unit 90a ON and OFF so that the power being supplied from the battery BA to the driving coils U, V, and W is carried out according to a predetermined timing scheme.

Consequently, a DC drive motor M is driven in a rotational manner by the power supply thereto from the battery BA such that the electric vehicle is driven.

On the other hand, in a regenerative braking mode, the duty factor of a pulse signal for controlling the power supplied to the drive motor M (driving duty factor) is reduced to zero. Upon the detection of the reduction of the driving duty factor to zero, a braking detecting device 79 produces a braking detection signal which is fed to the switching circuit 45c. The switching circuit 45c then selects the regenerative mode rectification control device 45b.

The regenerative mode rectification control device 45b switches the transistors ON and OFF so that regenerative power is produced by the drive motor M and consumed by the commutating/rectifying device 90 and the driving coils U, V, and W for braking.

In the regenerative braking mode, a three phase AC voltage as shown in Figure 6(a) is produced by the driving coils U, V, and W. During this state of operation, the regenerative mode rectification control device 45b feeds a pulse signal to the transistors UT_{r1} , VT_{r1} , and WT_{r1} so that these transistors are turned OFF. Moreover, the regenerative mode rectification control device 45b supplies a pulse signal, as shown in Figure 6(b), to the transistors UT_{r2} , VT_{r2} , and WT_{r2} so as to turn these transistors OFF and ON periodically and simultaneously.

When the transistors UT_{r2} , VT_{r2} , and WT_{r2} are turned OFF, currents induced in the driving coils tend to remain, and hence, a high voltage remains across each coil which can be utilized in recharging the battery BA.

Since the magnitude of the regenerative braking force is proportional to the energy consumed by the transistors, diodes, and driving coils while the transistors UT_{r2} , VT_{r2} , and WT_{r2} are switched ON, the magnitude of the regenerative braking force is proportional to the pulsewidth of the pulse

signal. Accordingly, the pulsewidth is increased when a large braking force is desired, and the pulsewidth is decreased or diminished, as shown in Figure 6(c), when a small braking force is desired.

The prior art device which utilizes this pulsewidth to control the braking force. However, such a method has encountered many problems in the actual regulation of the pulsewidth of the pulse signal. Since the induced current for recharging the battery BA is dependent upon the electromotive force of each coil when the transistors are turned OFF, the amount of charging energy is substantially constant regardless of the pulsewidth of the pulse signal. The only exception to this situation is when the pulsewidth is small and the electromotive force is in a transient state. Accordingly, the braking force and the recharging energy in the prior art devices could not be controlled individually.

Since the prior art devices were not able to control the braking force and the recharging energy individually, the prior art devices found it impossible to carry out a control operation, for example, which decreases the recharging energy when the battery is fully charged and increases the recharging energy when the battery is not fully charged notwithstanding the actual priority to be given to the controlling of the braking force.

More specifically, the prior art devices place the braking force as the highest priority and thus ignored the controlling of the recharging energy. Consequently, by ignoring the controlling of the recharging energy, either the battery became overcharged by regenerative braking when the battery was already basically overcharged or the battery could not be readily recharged to its full capacity if the battery was not already fully charged prior to the regenerative process.

Therefore, one embodiment of the present invention provides a regenerative braking control system for an electric vehicle which is capable of individually controlling the braking force and the recharging energy during a regenerative braking mode.

Figure 34 is a block diagram illustrating a portion of an electric system for controlling the driving of the drive motor of an electric vehicle. Driving coils U, V, and W are wound on a stator 37 of a drive motor M. A rotor 51 and a magnet rotor 48 are supported for rotation in a central portion of the stator 47. Hall-effect position sensors UH, VH, and WH determine, in a non-contactual manner, the angular position of the rotor 51. These position sensors provide position detection signals to a controller 10.

A driver 90 includes a switching circuit 90a which includes transistors and diodes and a pre-driving unit 90b. The driver 90 controls power supplied from a battery BA to the driving coils U, V,

and W. Moreover, the driver 90 controls the recharging of the battery BA by the energy generated in the driving coils.

A motor temperature sensor 21 detects the temperature of the drive motor M and produces a temperature signal TM representing the temperature of the drive motor and feeds this temperature signal to the controller 10. A throttle opening sensor 22 detects the opening of the throttle and produces a throttle opening signal TH which represents the actual opening of the throttle and feeds this signal to the controller 10. The controller 10 determines the rotor position based on the position signals received from the position sensors.

Figure 35 illustrates a table showing the detection signals provided by the position sensors and the corresponding angular positions of the rotor. For example, when the Hall-effect position sensors UH, VH, and WH detect an N-pole, an S-pole, and an S-pole, respectively, the rotor is at an angular position as illustrated by number 1 in Figure 35.

The controller 10 determines, on the basis of the throttle opening signal TH, whether the vehicle is in a driving mode (the vehicle is being driven by the drive motor) or whether the vehicle is in a braking mode (when the vehicle is being braked). If the vehicle is in the driving mode, the controller 10 produces output signals to be fed to the transistors of the switching unit 90a as illustrated in Figure 36.

These output signals are produced according to the angular position of the rotor 51. Moreover, the controller 10 controls the duty factor of a motor driving signal supplied to the drive motor M (driving duty factor) according to the throttle opening signal TH. Consequently, the magnitude of the power corresponding to the throttle opening is supplied from the battery BA to the drive motor M when the electric vehicle is in the driving mode.

During the braking mode, an electric brake is applied. Figures 6(a)-6(c) illustrate timing charts of the control mode for electrical braking. When power supplied to the drive motor M is terminated, three phase voltage, as shown in Figure 6(a) is generated in coils U, V, and W, respectively. During this electrical braking mode, the transistors UT_{r1} , VT_{r1} , and WT_{r1} are turned OFF. Also, a pulse signal, as illustrated in Figure 6(b), is applied to transistors UT_{r2} , VT_{r2} , and WT_{r2} to turn OFF and ON these transistors periodically and simultaneously. Consequently, the electromotive force generated by the coils is consumed as heat by the coils, transistors, and the diodes when the transistors UT_{r2} , VT_{r2} , and WT_{r2} are switched ON. This allows the drive motor M to be braked.

When these transistors are switched OFF, the currents induced in the coils tend to remain. This in turn maintains a high voltage across the terminals of each coil. If the voltage across the terminals of

each coil is higher than the supply voltage of the battery BA, the induced currents flow toward the battery BA to recharge this battery.

Since the braking force is proportional to the energy consumed by the transistors and diodes while the transistors UT_{r2} , VT_{r2} , and WT_{r2} are switched ON, the braking force is proportional to the duty factor of the pulse signal (braking duty factor). Accordingly, the braking duty factor is increased (the pulsewidth is increased) when a high braking force is necessary. Moreover, the braking duty factor is decreased (the pulsewidth is decreased) when a low braking force is necessary.

The prior art devices which utilize the system described above are also provided with a second controller for turning OFF all of the transistors of the driver 90 to stop the power from being supplied to the drive motor M, thereby preventing adverse effects upon the components of the electrical system when all of the position sensors produce the same position detection signals due to a malfunction or when the control of the power supplied to the drive motor becomes impossible. This hindrance of the controlling of the power supplied to the drive motor M may occur due to a malfunction of the throttle opening sensor or when the temperature of the drive motor increases excessively.

If all of the transistors of the driver 90 are turned OFF by the second controller when a portion of the electric system malfunctions, the driving wheels of the electric vehicle cannot be properly braked by using regenerative braking. Thus, the electric vehicle must be braked by using a mechanical braking system in order to stop the vehicle properly. In other words, the electric vehicle cannot decelerate in a satisfactory manner. Therefore, if all of the transistors of the driver 90 are turned OFF, the control of the electric vehicle according to the operations of the throttle, becomes impossible.

Accordingly, one embodiment of the present invention provides a controller for an electric vehicle which is capable of satisfactorily controlling the electric system of an electric vehicle even if a portion of the electric system for controlling the drive motor of the electric vehicle malfunctions.

OBJECTS AND SUMMARY OF THE PRESENT INVENTION

It is an object of the present invention to provide a regenerative braking control system for an electric vehicle which is capable of individually controlling the braking force and the recharging energy during regenerative braking.

It is another objective of the present invention to provide a controller for an electric vehicle which is capable of satisfactorily controlling the electric

system of the electric system when a portion of the electric vehicle for controlling the drive motor malfunctions.

To achieve one of the objects discussed above, the present invention provides a regenerative braking control system for an electric vehicle which consumes a portion of energy generated by the drive motor for braking and feeds a portion of the energy to a battery for recharging. This regenerative braking control system includes a braking period device for establishing a braking period that is started and ended within a half of a period of an AC voltage created in the coils. The system also includes a regenerative device for feeding an induced current corresponding to the energy stored in the coils at the end of a braking period to a battery and an energy consuming circuit for consuming the energy generated during the braking period.

When the braking operation is controlled by the regenerative braking control system described above, the braking force is proportional to the integral of the AC power consumed during the braking period. Moreover, the energy used to recharge the battery is dependent upon the electromotive force at the end of the braking period. Accordingly, the braking force and the recharging energy can be individually controlled by properly determining the starting time and ending time of the braking period.

Another embodiment of the present invention which achieves the object discussed above is a regenerative braking control system which includes a first braking period device for establishing a first braking period that is started within a half of a period of the AC voltage created in the coils, a second braking period device for establishing a second braking period that is ended within a half of a period of the AC voltage, a regenerative device for feeding the induced current corresponding to the energy stored in the coils at the end of the first braking period to the power supply, and an energy consuming circuit for consuming energy remaining at the end of the first braking period and the energy generated during the second braking period.

When the braking operation is controlled by the regenerative braking control system described above, the braking force is proportional to the integral of the AC power consumed during the first and second braking periods. The energy used to recharge the battery is dependent upon the electromotive force at the end of the first braking period. Accordingly, the braking force and the charging energy can be controlled individually by controlling the first and second braking periods.

A further embodiment of the present invention which controls regenerative braking includes a chopping device for chopping the braking period so

that the braking period consists of a plurality of intermittent short braking periods. When utilizing the chopping device in the regenerative braking operation, the recharging energy can be increased because a current is being induced at the end of every intermittent short braking period.

In still another embodiment of the present invention which realizes the objects discussed above is a controller which includes a monitor for monitoring the electric system to determine whether the electric system is functioning normally and an electrical braking device for electrically braking the drive motor when the monitor determines that the electric system or a portion of the electric system is malfunctioning.

When a controller is utilized as described above, the controller actuates the electric braking device upon the detection of the malfunction in the electric system. Accordingly, the vehicle can be decelerated in a satisfactory manner even if a portion of the electric system malfunctions while the vehicle is running.

Another embodiment of the present invention is a controller which includes a monitor for monitoring if the electric system is functioning normally and a correcting circuit for gradually decreasing the voltage used to control speed when a malfunction is detected by the monitor. This decreased voltage is applied to the drive motor when a malfunction is detected to control the motor's speed.

When utilizing this controller as described above, the malfunction of a portion of the electric system is detected by the monitor. Upon detecting this malfunction, the controller applies a voltage which is gradually decreasing. Accordingly, the power being supplied to the drive motor can be decreased without significantly deteriorating the controllability of the vehicle after a malfunction is detected in a portion of the electric system.

BRIEF DESCRIPTION OF THE DRAWINGS

Other objects and advantages of the present invention will become more apparent to those skilled in the art from the detailed description of the preferred embodiments with reference to the accompanied drawings wherein:

Figure 1 is a general view of an electric motorcycle incorporating the present invention;

Figure 2 is a sectional view of a power unit utilized by the present invention;

Figure 3 is another sectional view of a power unit utilized by the present invention;

Figure 4 is a third sectional view of a power unit utilized by the present invention;

Figure 5 is a block diagram illustrating a motor control system for an electric vehicle;

Figure 6 is a timing diagram illustrating a conventional control method for regenerative braking;

Figure 7 is a graphical representation of the concepts of the present invention;

Figure 8 is another graphical representation of the concepts of the present invention;

Figure 9 is a third graphical representation of the concepts of the present invention;

Figures 10(a)-10(d) are diagrams illustrating control modes according to the present invention;

Figure 11 is a circuit diagram illustrating another motor control system according to the present invention;

Figure 12 is a circuit diagram illustrating another motor control system according to the present invention;

Figure 13 is a timing diagram illustrating the operation of the motor control systems illustrated in Figures 11 and 12;

Figure 14 is a graph showing a relationship between decelerating torque and motor speed;

Figure 15 is a graph showing a relationship between motor speed and an angle $(\theta_1 + \theta_2)$;

Figure 16 is a graph showing a relationship between motor speed and an angle θ_1 ;

Figure 17 is a flow chart illustrating a regenerative braking control routine according to the present invention;

Figure 18 is a flow chart illustrating an interrupt sub-routine executed during a regenerative braking control routine according to the present invention;

Figure 19 is a flow chart illustrating an interrupt sub-routine executed during a regenerative braking control routine according to the present invention;

Figure 20 is a diagram illustrating a method for controlling angle θ_1 ;

Figures 21(a)-21(d) are diagrams illustrating control modes of other embodiments of the present invention;

Figure 22 is a block diagram of a motor control system according to the present invention;

Figure 23 illustrates an example of a duty factor map;

Figure 24 is a diagram illustrating a method for producing a duty factor map;

Figure 25 is a diagram illustrating another method for producing a duty factor map;

Figure 26 is a diagram illustrating a third method for producing a duty factor map;

Figure 27 is a diagram illustrating a fourth method for producing a duty factor map;

Figure 28 is a timing diagram illustrating a chopping control method according to another embodiment of the present invention;

Figure 29 is a block diagram of a third embodiment of the present invention;

Figure 30 is a block diagram of the driving signal output device illustrated in Figure 29;

Figure 31 is a flow chart illustrating the operations of the driving signal output device of Figure 29;

Figure 32 illustrates a throttle opening sensor;

Figures 33(a)-33(c) are charts illustrating other embodiments of the present invention;

Figure 34 is a block diagram of an electric control system employed in an electric vehicle;

Figure 35 is a table showing a relationship between signals provided by angular position sensors and an angular position of a rotor;

Figure 36 is a table illustrating the control of the drive motor according to an angular position of a rotor;

Figure 37 is a graph illustrating a relationship between a driving duty factor and a throttle opening signal; and

Figure 38 is a graph illustrating a relationship between a braking duty factor and a throttle opening signal.

DETAILED DESCRIPTION OF THE PRESENT INVENTION

Figure 1 is an illustration generally showing an electric motorcycle incorporating the present invention. The electric motorcycle X has a mainframe F consisting of a front frame F1, a middle frame F2, and a rear frame F3. Each frame is formed of steel pipes. Main frame F is covered with a leg shelf B1, a step floor B2, a rear cover B3, and an undercover B4.

A steering device 2 is attached to the upper end of a head pipe 1 and fixed to the front frame F1. A front fork 4 for suspending a front wheel WF by a front shock absorber 3 is joined for turning the lower end of the head pipe 1. A swing power unit P has a front end pivotally joined to the rear end of the metal frame F2 by a pivot 5. A rear end of the swing power unit P supports a rear wheel WR by a rear axle. The power unit P swings vertically on the pivot 5. A rear shock absorber 6 has a lower end joined to the upper surface of the rear portion of the power unit P and an upper end joined to the rear frame F3.

A stand 7 is connected to the middle frame F2 so as to cover the front lower surface of the power unit to serve as a protective member which protects the drive unit of the power unit P. A storage box 9 for containing a helmet and other items is provided between the power unit P and a seat 8. The storage box 9 is formed of a material capable of magnetic shielding, such as a conductive resin, to protect the contents from the magnetism of the

drive motor M.

A battery box 10 contains a battery for supplying power to the drive motor and is supported on the middle frame F2. A controller 11 for controlling the drive motor M and a recharger 12 for recharging the battery are provided in front of the head pipe 1.

The power unit P has a front transmission case 13. The pivot 5 extends laterally through the transmission case 13. The drive motor M is placed in front of the transmission case 13. A reduction gear 14 is placed in the rear portion of the transmission case 13. The drive motor M and the reduction gear 14 are interlocked by a belt-type continuously variable speed transmission 15. The transmission case 13 is divided into a left hand transmission chamber 13b for containing the belt-type continuously variable speed transmission 15 and a right hand motor chamber 13c for containing the drive motor M. The transmission case is divided by a partition wall 13a.

A motor housing 16 housing the drive motor M is placed in the motor chamber 13c. A driver housing 13d forms a portion of the transmission case 13 and contains a driver 25. This driver housing 13d is joined to the right end surface of the motor housing 16 and is fastened to the motor housing by bolts 8. The rotor shaft 19 of the drive motor M is supported by a ball bearing 20 provided in the motor housing 16 and is further supported by a ball bearing 21 provided on the inner wall of the transmission case 13.

A cooling fan 22 is mounted on the right hand of the rotor shaft 19 within the motor housing 16. A flexible duct 23 for introducing cooling air into the motor chamber 13c has a lower end joined to the upper wall of the transmission case 13 at the position between the drive motor M and the belt-type continuously variable speed transmission 15. Also, the flexible duct 23 has an upper end opening into the storage box 9.

Referring to Figures 2, 3, and 4, the driver 25 having a substantially hexagonal shape is disposed coaxially with the rotor shaft 19 and the driver housing 13(d). The driver 25 is also fastened to the motor housing 16 with bolts 24. A plurality of cooling fans 26 project from the inner surfaces of the sides of the driver 25.

Field Effect Transistors (FETS) are attached to the outer surface of the driver 25. A capacitor 28 having a large capacitance is firmly fitted in the central space of the driver. The right hand open end at the motor housing 16 is covered with a cover provided with a discharge opening 29a which includes louvers.

Drive motor M is a DC brushless motor having a rotor 33 formed by arranging permanent magnets 32 on an outer circumference of a core 31 fixedly mounted on the rotor shaft 19. Stator 37 is formed

by winding coil 36 on a core 35 disposed within and fastened to the motor housing 16 with bolts 34. The angular position sensor 40 detects the angular position of the rotor 33. A magnet rotor 48 is fixedly mounted on the rotor shaft 19. Three Hall-effect devices 39(UH, VH, and WH) are disposed opposite to the outer circumference of a magnet rotor 48.

Cooling air is introduced through the storage box 9 and the duct 23 into the motor chamber 13c by the cooling fan 22. This cooling air cools the drive motor M and flows through hole 16a formed in the motor housing 16 and into the driver housing 13d. Moreover, the cooling air cools the FETS 27 and the capacitor 28 before flowing outside through the discharge opening 29a of the cover 29.

Referring to Figures 2 and 3, the belt-type continuously variable speed transmission 15 has a driving pulley 61 mounted on a portion of the rotor shaft 15 projecting into the transmission case 13. A driven pulley 63 is mounted on the input shaft 62 of the reduction gear 14 supported on the rear portion of the transmission case 13. An endless belt 64 is extended between the pulleys 61 and 63.

The driving pulley 61 consists of a fixed pulley element 61a connected to the rotor shaft 19 and a moveable pulley element 61b actually slidable mounted on the rotor shaft 19. Centrifugal weights 66 are provided to move radially between the moveable pulley element 61b and a ramp plate 65 fixed to the rotor shaft 15.

The driven pulley 63 consists of a fixed pulley element 63a placed on a collar 68. A needle bearing 67 on the input shaft 62 of the reduction gear 14 is supported for rotation relative to the input shaft 62 of the reduction gear 14. A moveable pulley element 63b is mounted on the collar 68 for axial movement thereon. A driving force is transmitted from the rotor shaft 19 to the driven pulley 63 through an automatic centrifugal clutch 69 and the input shaft 62. The driving force from the input shaft 62 of the reduction gear 14 is transmitted through another automatic centrifugal clutch 70 to the driven pulley 63.

The input shaft 62 of the reduction gear 14 is supported by a pair of ball bearings 71 and 72 provided on the transmission case 13. Intermediate shaft 76 is supported on the transmission case 13 between the input shaft 62 and a rear axle 75 supported by a pair of ball bearings 73 and 74. Moreover, these ball bearings 73 and 74 support the rear wheel WR. The rotation of a driving gear 77 mounted on the input shaft 62 is transmitted by two intermediate gears 78 and 79 mounted on the intermediate shaft 76 to a driven gear 80 fixed to the rear axle 75.

When the motor speed of the drive motor M is low, the automatic centrifugal clutch 69 remains

disengaged, and hence, the driving force of the drive motor is not transmitted to the rear wheel WR. As the motor speed of the drive motor increases, the centrifugal weights move radially outward along the ramp plate 65 fixed to the rotor shaft 19 to shift the moveable pulley element 61b of the driving pulley 61 toward the fixed pulley element 61a. Consequently, the effective radius of the driving pulley 61 increases while the moveable pulley element 63b of the driven pulley 63 is shifted away from the fixed pulley element 63a by the endless belt 64, thereby decreasing the effective radius of the driven pulley 63. Thus, the operative ratio of the belt-type continuously variable speed transmission 15 is decreased to increase the rotating speed of the collar 68 which rotates together with the driven pulley 63. Subsequently, the automatic centrifugal clutch 69 is engaged to transmit the driving force of the drive motor M to the input shaft 62 of the reduction gear 14, and consequently, the rear wheel WR is driven.

Clean air prevailing in the storage box 9 is introduced through the duct 23 into the motor chamber 13c of the transmission case 13 by the cooling fan 22 which rotates together with the rotor motor shaft 19 of the drive motor M. The cooling air removes heat generated by the coils 36 of the drive motor M. This cooling air flows through the hole 16a formed in the motor housing 16 and into the driver housing 13d. Moreover, the cooling air flows along the outer circumference of the driver 25 and through spaces between the cooling fans 26 to cool the FETS 27 and the capacitor 28. Lastly, the cooling air flows outside through the discharge opening 29a of the cover 29.

Since the duct 23 which guides the cooling air into the transmission case 13 is joined to the upper wall of the transmission case 13 at the position between the drive motor M and the belt-type continuously variable speed transmission 13, the duct does not protrude laterally from the transmission case 13 to increase the overall width of the transmission case. The dead space between the drive motor M and the belt-type continuously variable speed transmission 15 can effectively be utilized.

A control system for controlling the running of the electric motorcycle driven by the energy stored in the battery BA will be described below. In the following description, the duty factor of the pulse signal for controlling the power supplied to the drive motor M will be referred to simply as duty factor.

Figure 22 is a functional block diagram of a motor driving system which illustrates only the functions necessary for driving the drive motor M by the power supplied from the battery. Referring to Figure 22, a speed detecting device 101 detects the motor speed N, i.e., the rotating speed of the

rotor shaft 19 of the drive motor M. A throttle opening detecting device 102 detects a throttle opening θ_{th} . A battery voltage detecting device 103 detects the battery voltage. A duty factor map storage device 106 stores data $D(x,y)$ which represents the duty factors as a function of motor speed N_e and a throttle opening θ_{th} , as shown in Figure 23.

A duty factor calculating circuit 104 chooses duty factor data $D(x,y)$ which corresponds to the detected motor speed N_e and the detected throttle opening θ_{th} from the duty factor map storage device 106. If any duty factor data $D(x,y)$ which correspond to the detected motor speed N_e and the detected throttle opening θ_{th} is not found in the duty factor map storage device, optimal duty factor data $D(x,y)$ is calculated by interpolation.

A voltage correcting device 105 corrects a duty factor so that a desired motor output is obtained regardless of the battery voltage. The output of the drive motor is controlled by varying the duty factor of the pulse signal, the output of the drive motor decreases when the battery voltage drops below a standard voltage even if the duty factor is held constant. Accordingly, the present invention regulates the duty factor so that the duty factor is increased when the battery voltage is low and the duty factor decreases when the battery voltage is high so as to maintain the desired output of the drive motor regardless of the battery voltage.

In other words, the present invention corrects the duty factor by multiplying the calculated duty factor by a reference voltage and dividing the product of this multiplication by the battery voltage. This calculation gives the present invention the corrected duty factor. By utilizing the corrected duty factor, the desired output of the motor factor can be obtained regardless of the variation in the battery voltage.

Since the present invention determines the duty factor as a function of the motor speed N_e and the throttle opening θ_{th} , the following various control operations are able to be accomplished.

Figure 24 shows an example of the duty factor data map stored in the duty factor map storage device 106.

The present invention chooses a small duty factor regardless of the throttle opening θ_{th} at the starting of the drive motor or while the motor speed is low. Although, normally, a high current corresponding to a locking current tends to flow through the drive motor due to the inertial mass of the rotor when starting the drive motor, the present invention chooses a small duty factor during the starting of the drive motor and during low speed operations to inhibit a high current from flowing through the drive motor. Selection of the duty factor for maintaining the efficiency of the drive motor on a sufficiently

high level will be described below.

Graph(a) of Figure 25 illustrates the general relationship between the motor speed N_e , motor output P , and efficiency η . Since the electric vehicle requires a large torque when starting the electric vehicle, a characteristic of the motor output P , as shown in graph(a) of Figure 25, has been used. In other words, the higher the torque is and the lower the motor speed N_e is, a sufficiently high acceleration can be realized by utilizing this characteristic. However, if this characteristic is utilized during the starting of the electric vehicle, the efficiency η of the drive motor is greatly deteriorated.

The present invention determines the relationship between the motor speed N_e (when the motor efficiency η is 70%) and the throttle opening θ_{th} is at a maximum and the duty factor as shown in graph(b) of Figure 25. This relationship is stored in the duty factor map storage device 106 wherein the present invention chooses a duty factor corresponding to the motor speed N_e so that the drive motor operates at an efficiency not lower than 70%.

A duty factor corresponding to a throttle opening smaller than the maximum throttle opening is smaller than a duty factor corresponding to the maximum throttle opening. Since the duty factor is regulated so that the area under a curve representing the conditions for maintaining a 70% efficiency is satisfied, the efficiency is not lower than 70% for any throttle opening lower than the maximum throttle opening if the relationship for the maximum throttle opening is determined.

A method for setting the duty factor to control the running speed during acceleration will be described below. Figure 26 shows the variation of the motor output P with the motor speed N_e for the duty factor K and running resistance R at a medium throttle opening.

A duty factor for operation with a medium throttle opening can be freely chosen, relatively, for operation at an efficiency exceeding 70% by using a duty factor map. However, if the relationship between the motor output P and the motor speed N_e is represented by a curve 1, the electric vehicle may be accelerated smoothly because acceleration, the difference between curve 1 and the running resistance R , is small in the initial stage of acceleration.

However, it is not preferable to control the running speed because acceleration increases gradually after the initial stage of acceleration. The present invention employs a duty factor map so that the relationship between the motor output P and the motor speed N_e at a medium throttle opening is similar to curve 2. This enables the acceleration (curve 2 - running resistance) to be high in the initial stage of acceleration and enables

the acceleration to decrease with an increase in running speed.

A method for setting the duty factor to alleviate the problems of running speed at the start of the electric vehicle due to a difference between the throttle opening θ_{th} and the start of the electric vehicle will be described below.

When the relationship between a throttle opening θ_{th} and the duty factor K is as represented by a dotted line 1 in Figure 27, the electric vehicle employing a centrifugal clutch does not start running even if the throttle opening θ_{th} is increased gradually such that the duty factor K reaches a lower limit K(L) corresponding to a motor speed necessary for engaging the centrifugal clutch so that power can be transmitted. Accordingly, the range d1 during idle operations of the drive motor, a time interval from the opening of the throttle to start the drive motor, and the increase of the duty factor K to the lower limit K(L) is unsatisfactory. When a conventional vehicle is not running, the engine is kept operating for idling purposes.

Therefore, the increment of the throttle opening necessary for increasing the engine speed to a value sufficient for the clutch to transmit power is not very large. Hence, the disparity between the operation of throttle and the response of the vehicle is not very significant. If the drive motor is kept running for idling even while the throttle is fully closed, the unsatisfactory performance when starting an electric vehicle may be eliminated.

However, the operation of the drive motor for idling increases power consumption and thus reduces the distance that the vehicle can travel without recharging the battery. Accordingly, the present invention controls a duty factor K so that the duty factor K increases instantaneously to a threshold K(S) slightly smaller than the lower limit K(L) upon the increase of the throttle opening θ_{th} corresponding to a starting motor speed as indicated by continuous line 2 in Figure 27. Thus, the range d2 for idling operations of the drive motor, a time interval from the start of the drive motor to the start of the electric vehicle, is curtailed to eliminate any unsatisfactory operations.

Figures 7, 8, and 9 are graphs illustrating the basic concepts of the present invention. In the following description, one period of an AC electromotive force produced in coil U corresponds to an electrical angle range of 0° to 360° and a mechanical angle range of 0° to 180° , an ON period of the transistors to be started at an electrical angle 0° within the electrical angle range of 0° to 90° is represented by angle θ_1 , and an ON period of the transistors to be ended within an electrical angle 180° of the electrical angle range of 90° to 180° is represented by an angle θ_2 . A recharging current I is supplied to the battery BA

wherein this recharging current was induced in the coils when the transistors are turned OFF. Therefore, the magnitude of the recharging current I is proportional to the electromotive force of the coil immediately before the transistors are switched OFF. Accordingly, it is desirable that the angle θ_1 be nearly equal to 90° as shown in Figure 7 when it is desirable to have the recharging current I at its maximum.

The regenerative torque, the braking force, is proportional to the amount of energy consumed by the transistors, diodes, and coils when the transistors are in the ON state. This amount of energy is equal to the integral S_1 of the electromotive force induced in the coils when the transistors are in the ON state. Accordingly, it is desirable to increase the angle θ_1 , as shown in Figure 7, when it is desired to have maximum braking force.

If only angle θ_1 is used in controlling the operations of the electric vehicle, it is impossible to control the operations for decreasing recharging current and at the same time increasing braking force or vice versa. Accordingly, the present invention employs a second angle θ_2 for individually controlling the recharging current and the braking force.

If the transistors are switched OFF always at an electrical angle of 180° within an electrical angle range of 90° to 180° , the induced current is zero, and hence, the recharging current is always zero. However, the braking force is dependent upon the integral S_2 of the electromotive force as illustrated in Figure 9. The present invention controls the angles of θ_1 and θ_2 individually for each coil to control the recharging current and the braking force individually.

Figures 10(a)-10(d) illustrate the control diagrams for individually controlling the recharging current and the braking force by individually controlling the angles θ_1 and θ_2 for each coil. In other words, when both angles θ_1 and θ_2 are increased, both the recharging current and the braking force are increased. Moreover, when angle θ_1 is increased and angle θ_2 is decreased, the recharging current is increased and the braking force is decreased. When the angle θ_1 is decreased and the angle θ_2 is increased, the recharging current is decreased and the braking force is increased. Lastly, when both angles θ_1 and θ_2 are decreased, both the recharging current and the braking force are decreased.

Figures 11 and 12 are circuit diagrams illustrating the principle portion of the motor control system described with reference to Figure 5. Figure 13 is a timing diagram of the operations to be carried out by the motor control system.

In Figure 13, UH, VH, and WH are respective output signals of the Hall-effect devices UH, VH,

and WH. Although the DC motor has driving coils U, V, and W in a three phase construction, circuits relating mainly to coil U will be described below because each phase is constructed the same.

During the period corresponding to the angle θ_1 , the transistors UTr_1 , VTr_1 and WTr_1 are turned OFF and only the transistor UTr_2 is switched ON. Therefore, a closed circuit consisting of coil U, transistor UTr_2 , diode VD_2 and coil V and a closed circuit consisting of coil W, transistor WTr_2 , diode VD_2 and coil D are formed as shown in Figure 11. Accordingly, the electromotive force produced in each coil is converted into heat by the coils, transistors, and diodes, thereby enabling braking.

When the transistor UTr_2 is switched OFF at the end of the period corresponding to the angle θ_1 , a current induced in each coil will be maintained, and hence, a high voltage will appear across the terminals of each coil. If the voltage appearing across the terminals of each coil is higher than the output voltage of the battery BA, a closed circuit consisting of coil U, diode VD_1 , battery BA, diode VD_2 and coil B is formed so that the battery BA is recharged with the current. Thereafter, neither recharging current nor a braking force is produced until the start of the period corresponding to the angle θ_2 .

When the transistor UTr_2 is switched ON at the start of the period corresponding to the angle θ_2 , the same closed circuit, as described above, is formed for braking. When the transistor UTr_2 is switched OFF at the end of the period corresponding to the angle θ_2 , no electromotive force is produced in coil U, and hence, no recharging current is induced. Accordingly, if a recharging current is controlled preferentially by angle θ_1 and angle θ_2 is determined so as to supplement a deficiency in the braking force, both the recharging current and the braking force can be controlled individually.

The decelerating torque in the full regenerative braking mode increases according to the motor speed N_e until the motor speed N_e reaches its peak N_{e1} , as indicated by the continuous line in Figure 14. Moreover, the decelerating torque decreases gradually with the increase of the motor speed N_e after the motor speed N_e has exceeded speed N_{e1} . However, it is desirable that the decelerating torque increases continuously according to the motor speed N_e so that the rate of the motor speed decreases gradually with the increase of the motor speed N_e as indicated by a dotted line in Figure 14.

In this embodiment of the present invention, angle $(\theta_1 + \theta_2)$ is decreased with the increase of the motor speed N_e until the motor speed N_e reaches the motor speed N_{e1} as illustrated in Figure 15. The angle $(\theta_1 + \theta_2)$ is increased gradually after the motor speed N_e has exceeded speed N_{e1}

as also illustrated in Figure 15. This is a function of $f(N_e)$ which characteristic is illustrated by the dotted line in Figure 14. An ideal decelerating torque characteristic as a function of the motor speed N_e can be attained by such control of the angles θ_1 and θ_2 so that the controllability of the motor speed is improved.

Angle θ_1 is decreased gradually with the increase of the motor speed N_e as a function $g(N_e)$ as shown in Figure 16 so that the voltage of the battery BA is held constant during regenerative braking.

Figure 17 is a flow chart showing the control of regenerative braking operations. Figures 18 and 19 are flow charts illustrating interrupt sub-routines to be executed at predetermined times during the control cycle.

The motor control system starts the control operations when connected to a power supply. In step S10, a throttle opening θ_{th} is detected, and the driving duty factor is determined on the basis of a throttle opening and the motor speed N_e in step S11.

At step S12, it is determined if the driving duty factor is greater than zero. Step S17 is executed if the response in step S12 is affirmative and it is determined that the electric motorcycle is running. Step S13 is executed for regenerative braking if the response in step S12 is negative.

In step S17, the transistors UTr_1 , VTr_1 , WTr_1 , UTr_2 , VTr_2 , and WTr_2 , are switched OFF and ON properly to drive the drive motor. After the execution of step S17, the routine returns to step S10.

In step S13, the transistors UTr_1 , VTr_1 , and WTr_1 are switched OFF. In step S14, the battery voltage is detected to determine if the battery BA is fully charged. Step S15 is executed if the battery BA is fully charged. Step S16 is executed when the battery BA is not fully charged.

In step S15, the angle θ_1 is set to zero and angle θ_2 is set at an angle determined by the function $f(N_e)$ as shown in Figure 15.

In step S16, the angle θ_1 is set at an angle determined by the function $g(N_e)$ as shown in Figure 16. Since the braking force is effective during a period corresponding to angle θ_1 , angle θ_2 is set at an angle determined by subtracting the angle θ_1 from the angle determined by the function $f(N_e)$ as illustrated in Figure 15.

Upon the detection of the leading edge of the output signal of the Hall-effect device UH, the interruption sub-routine of Figure 18 is executed at step S20 to determine the motor speed N_e and the transistor UTr_2 is switched OFF at step S21.

At step S22, a time $T1$ necessary for setting the angle θ_1 as determined in step S14 or S15 of the main routing is calculated. A time $T2$ necessary for setting the angle θ_2 is also calculated at step

S23.

As shown in Figure 13, the time T1 corresponds to the angle θ_1 , and time T2 corresponds to a time from the detection of the leading edge of the output signal of the Hall-effect device UH to the start of the period corresponding to angle θ_2 .

Upon a detection of the leading edge of the output of the signal of the Hall-effect device, UH, the interrupt sub-routine of Figure 19 is executed. In step S30, the transistor UTr_2 is switched ON to start a period corresponding to angle θ_1 . The measuring of time T1 is started at step S31, and the measuring of time T2 is started at step S32.

Upon the detection of the termination of the period corresponding to angle θ_1 , the transistor UTr_2 is turned OFF. Upon the detection of the termination of the period corresponding to angle θ_2 , the transistor UTr_2 is switched ON again to start the period corresponding to angle θ_2 .

Although this embodiment of the present invention determines angle θ_1 as a function of only the motor speed N_e , the angle θ_1 may be a function of the motor speed N_e and the battery voltage.

Figure 20 illustrates a method for control of angle θ_1 in another embodiment of the present invention. This embodiment of the present invention detects the battery voltage, and angle θ_1 is decreased gradually with the increase of the battery voltage. Thus, a recharging current is optimized so that the recharging current is increased when the battery voltage is low or the battery is not charged to its full capacity. The recharging current is decreased when the battery voltage is high or the battery is fully charged. On the other hand, as mentioned above, angle θ_2 is set at an angle determined by subtracting angle θ_1 from an angle determined by the function $f(N_e)$, as shown in Figure 15, to obtain an optimal braking force and an optimal recharging current.

In this embodiment, the period corresponding to the angle θ_1 is ended in the initial half (before an electrical angle 90°) of a half of a period of the AC voltage induced in the current coil. However, the periods, respectively, corresponding to angles θ_1 or θ_2 may be ended or started at appropriate angles within the range of electric angles 0° to 180° . Furthermore, the electric angle θ_1 or θ_2 may be substituted by a single angle θ_3 which represents a period to be started within a half of a period (a period corresponding to the range of the electrical angle of 0° to 180°) of the AC voltage induced in the coil. The time for starting the period corresponding to angle θ_3 and the time for ending the period corresponding to angle θ_3 may be determined properly so that individual control of the braking force and recharging current can be realized.

Figures 21(a)-21(d) illustrate control modes for individually controlling braking force and recharging current by properly setting the angle θ_3 . The period corresponding to angle θ_3 is started at an electrical angle nearly equal to an electrical angle of 90° and is ended at an electrical angle nearly equal to an electrical angle of 180° to obtain a high braking force and a low recharging current (Figure 21(a)). The period corresponding to angle θ_3 is started at an electrical angle nearly equal to an electrical angle of 0° and is ended at an electrical angle nearly equal to an electrical angle of 90° to obtain a high braking force and a high recharging current (Figure 21(b)). The period corresponding to angle θ_3 is ended at an electrical angle nearly equal to an electrical angle of 90° and is started just before the electrical angle at which the period is ended to obtain a low braking force and a high recharging current (Figure 21(c)). The period corresponding to angle θ_3 is ended at an electrical angle nearly equal to an electrical angle of 180° and is started just before the electrical angle at which the period is ended to obtain a low braking force and a low recharging current (Figure 21(d)).

This embodiment of the present invention controls the electrical angle at which the period corresponding to the angle θ_3 is started to control braking force and controls the electrical angle at which the period corresponding to the angle θ_3 is ended to control recharging current. This enables individual determination of the braking force and recharging current.

Angle θ_3 is decreased with the increase of the motor speed N_e until the motor speed N_e reaches the predetermined speed N_{e1} and is increased gradually after the motor speed N_e has exceeded the speed N_{e1} as mentioned above. In the foregoing embodiments, the transistors UTr_2 , VTr_2 , and WTr_2 are switched ON during the braking periods, respectively, corresponding to angles θ_1 , θ_2 , and θ_3 . However, when the transistors are controlled in such a manner, the recharging current used to recharge the battery BA is induced only once in the half of a period of the AC voltage at the end of the period corresponding to angle θ_1 or θ_3 , and hence, it is impossible to obtain a large recharging current.

Accordingly, in a further embodiment of the present invention, the transistors UTr_2 , VTr_2 , and WTr_2 are controlled using a chopping mode during the period corresponding to angle θ_1 , θ_2 , or θ_3 so that the braking period consists of a plurality of intermittent short braking periods. Thus, the frequency of inducing a current is increased to obtain a higher recharging current.

Figure 28 is a timing diagram showing the chopping control of the transistor UTr_2 , VTr_2 , and WTr_2 , corresponding to angle θ_1 . This embodiment

increases the frequency of the inducing current and the braking period corresponding to angle θ_1 , thereby increasing the recharging current substantially by chopping the control of the transistors UTr_2 , VTr_2 , and WTr_2 corresponding to angle θ_1 .

It is also possible to increase the recharging current substantially by increasing the inducing current in the period corresponding to angle θ_3 by chopping the control of transistors UTr_2 , VTr_2 , and WTr_2 during the braking period corresponding to angle θ_3 . It is desirable to execute this chopping control as explained above only when a high recharging current is necessary. Thus, the chopping control should be avoided when a low recharging current is necessary. Furthermore, if a higher recharging current is necessary, the chopping control may be executed in the period corresponding to angle θ_2 in addition to the chopping control and the periods corresponding to angles θ_1 and θ_3 .

Figure 29 is a block diagram showing the functions of a portion of a controller in another preferred embodiment of the present invention corresponding to the controller 10 as previously described with reference to Figure 34.

An angular position detecting device 101 determines the angular position of the rotor on the basis of the angular position detection signals provided by angular position sensors and generates an angular position signal for a driving signal output device 105. If the angular position detection signals provided by the angular position sensors are all the same, the angular position detecting device 101 produces an angular position coincidence signal and feeds this coincidence signal to a monitor 102. When either the angular position coincidence signal, a throttle opening signal TH representing the opening of a throttle being outside a reference range, a temperature signal TM representing a temperature of the drive motor being higher than an upper limit temperature, or a signal representing the output voltage of a battery being lower than a lower limit is fed to the monitor 102, the monitor 102 produces a monitor signal for the driving signal output device 105 and feeds the input throttle opening signal TH to a driving duty factor determining device 103 and a braking duty factor determining device 104.

Figure 32 illustrates a throttle opening sensor. A potentiometer 143 is connected operatively to a throttle grip 141. The resistance of the potentiometer varies according to the angular position of the throttle grip 41. The output voltage of the potentiometer 143 is fed as the throttle opening signal TH to the driving signal output device 105. The angular turning range of the throttle grip 41 is defined by stoppers 142a and 142b so that the output voltage of the potentiometer 143 is in a range of, for example, 0.5 volts to 4.5 volts. Ac-

cordingly, if a voltage outside the range of the potentiometer 143 is detected by the driving signal output device 105, it is determined that the throttle opening sensor is not functioning normally.

The driving duty factor determining device 103 and the brake duty factor determining device 104 determine the driving duty factor and the brake duty factor, respectively, on the basis of the throttle opening signal TH as shown in Figures 38 and 39. The driving signal output device 105 switches ON and OFF the transistors of a driver 90 according to the angular position of the rotor, the driving duty factor, the braking duty factor, and the monitor signal.

Figure 30 is a block diagram of the driving signal output device 105, and Figure 31 is a flow chart illustrating the operations of the driving signal output device 105.

In step S110, a driving duty factor, a braking duty factor, and a monitor signal are fed to a driving/braking/monitoring determining device 105b. At step S111, it is determined, on the basis of the monitor signal, if an electric control system for controlling the drive motor is functioning normally. If the electric control system is functioning normally, it is determined at step S112 if the driving duty factor is zero.

If the determination at step S112 is negative, the driving duty factor is fed as an output duty factor from a pulse signal generating device, 105c, to AND gates 105d in step S113. At step S116, a driving mode signal, i.e., a mode signal indicating a driving mode, is fed to an ON/OFF decision device 105a.

If the determination in step S112 is affirmative (the driving duty factor is zero), the braking duty factor (Step S114) is fed as an output duty factor to the pulse signal generating device 105c. The pulse signal generating device 105c applies a pulse signal having the braking duty factor to AND gates 105d.

If the determination in step S111 is negative (the electric control system is not functioning normally), a predetermined duty factor (Step S115) is fed to the pulse signal generating device 105c. The pulse signal generating device 105c then applies a pulse signal having the predetermined duty factor to AND gates 105d.

In step S117, a braking mode signal, a mode signal indicating a braking mode, is fed to the ON/OFF decision device 105a.

In step S118, the ON/OFF decision device 105a receives the mode signal and the angular position signal. In step S119, it is determined whether the mode signal is a braking mode signal. If the determination of step S119 is affirmative, step S121 is executed so as to set the driving signals $U+$, $V+$, and $W+$ to be low and driving

signals U-, V-, and W- as high. Consequently, only the transistors UT_{r2} , VT_{r2} , and WT_{r2} of the driver 90 are switched ON for electrical braking.

On the other hand, if the mode signal is a driving mode signal, a driving signal described with respect to Figure 36 is provided at step S120. Consequently, the AND gates 105d provide a pulse signal having the predetermined duty factor to control the ON/OFF of the transistors.

The electric vehicle is braked electrically by regenerative braking or dynamic braking when the electric control system for controlling the drive motor is not functioning normally. Accordingly, the electric vehicle can be decelerated in a satisfactory manner even if a portion of the electric control system malfunctions while the electric vehicle is running. Incidentally, the controller in this embodiment of the present invention starts the braking operation upon the detection of the malfunction of the portion of the electric control system.

However, in some cases, it is more preferable to maintain the running mode than to brake the electric vehicle immediately under a condition that will not effect normal portions of the electric control system, such as a condition and which the temperature of the driving motor has increased beyond a normal temperature or a condition in which the output voltage of the battery has dropped below a normal voltage.

A controller for an electric vehicle, according to another embodiment of the present invention, maintains the present running mode for a while after the malfunction of the portion of the electric control system has been detected.

Figures 33(a)-33(c) are diagrams illustrating the controller of this embodiment of the present invention in which Figure 33(a) illustrates the variation of the throttle opening signal TH representing the opening of the throttle with time, Figure 33(b) illustrates the variation of the correction factor K for multiplying the throttle opening signal TH with time, and Figure 33(c) illustrates a variation of a corrected output obtained by multiplying the throttle opening signal TH by the correction coefficient with time.

In this embodiment, the throttle opening signal TH is multiplied by the correction factor K which decreases gradually from 100% after the detection of the malfunction of a portion of the electric control system. The power supplied to the drive motor is controlled on the basis of the corrected throttle opening signal. Although the power supplied to the drive motor is decreased gradually after the detection of the malfunction of the portion of the electric control system, the controllability is not significantly affected because to control to drive motor according to the operations of the throttle is possible.

Accordingly, it is possible to move the electric vehicle to a desired place by operating the throttle even after the malfunction of a portion of the electric control system. The electric vehicle can satisfactorily be decelerated by electrically braking the electric vehicle in the braking mode as described above even if a portion of the electric control system malfunctions while the electric vehicle is running.

As is apparent from the description given above, the present invention has the following effects.

The preferential control of the recharging current through the control of time at which a period corresponding to θ_1 is to be ended and the control of time at which a period corresponding to the angle θ_2 is to be started so that inefficient braking force obtained during the period corresponding to the angle is supplemented, thereby enabling the individual determination of the braking force and individually controlling the recharging energy during the regenerated braking mode.

The control of the recharging current through the control of time at which a period corresponding to the angle θ_3 is to be ended and the control of the braking force through the control of the time at which the period corresponding to angle θ_3 is to be started enables individual control of the braking force and recharging energy during the regenerative braking mode.

The chopping control of the transistors during the periods, respectively, corresponding to angles θ_1 , θ_2 , and θ_3 and the control of the braking force through the control of the starting time, increases the frequency at which the induced current is produced, thereby enhancing the recharging current.

The electric vehicle can be satisfactorily decelerated even if a portion of the electric control system malfunctions while the vehicle is running because the electric vehicle is braked electrically when a portion of the electric control system controlling the drive motor malfunctions.

The controllability is not significantly hindered and appropriate measures can be taken when the electric control system malfunctions because a throttle opening signal is multiplied by a correction coefficient which gradually decreases. The power supplied to the drive motor is controlled according to the corrected throttle opening signal after the malfunction of the electric control system.

While only certain embodiments of the present invention have been described, it will be apparent to those skilled in the art that various changes and modifications may be made therein without departing from the spirit and scope of the present invention as set forth in the claims below.

Claims

1. A controller for an electric vehicle driven by an electric motor the speed of which is controlled according to a voltage comprising:
 - monitor means (102) for monitoring functions of the electric vehicle to detect a malfunction therein; and
 - correcting means (105) for generating a corrected voltage by gradually decreasing the voltage for controlling speed when the malfunction is detected by said monitor means (102);
 - said correcting means (104, 105) supplying said corrected voltage to the electric motor (M) when the malfunction is detected.
2. The controller as claimed in claim 1, further comprising:
 - an electrical braking means (104) for electrically braking the drive motor when a malfunction is detected by said monitor means (102).
3. The controller as claimed in claim 2, said electric braking means (104) being applied when said corrected voltage is zero volts.
4. The controller as claimed in claim 1, wherein said monitor means comprises:
 - a first monitor means for detecting a first malfunction in the electric vehicle, said first malfunction immediately affecting other functions of the electric vehicle from being performed normally;
 - a second monitor means for detecting a second malfunction in the electric vehicle, said second malfunction allowing other functions of the electric vehicle to be performed normally;
 - electric braking means (104) for electrically braking the electric motor (M); and
 - correcting means (105) for generating a corrected voltage by gradually decreasing the voltage which controls the speed when said second malfunction is detected by said second monitor means;
 - said electric braking means (104) being actuated when said first malfunction is detected by said first monitor means;
 - said correcting means (105) applying said corrected voltage to the electric motor to control the speed when said second malfunction is detected.
5. The controller as claimed in claim 4, wherein said electric braking means (104) is actuated when said corrected voltage decreases to zero volts.
6. The controller as claimed in any of claims 1 to 5, wherein said electric braking is dynamic braking.
7. The controller as claimed in any of claims 1 to 5, wherein said electric braking is regenerative braking.
8. A method for controlling an electric vehicle driven by an electric motor the speed of which is controlled according to a voltage, comprising the steps of:
 - (a) monitoring functions of the electric vehicle to detect a malfunction therein;
 - (b) generating a corrected voltage by gradually decreasing the voltage for controlling speed when the malfunction is detected by said step (a); and
 - (c) supplying the corrected voltage to the electric motor when the malfunction is detected.
9. The method as claimed in claim 8, further comprising the step of:
 - electrically braking the drive motor (M) when a malfunction is detected in said step (a).
10. The method as claimed in claim 8, further comprising the step of:
 - (d) electrically braking the electric motor when the corrected voltage is zero volts.
11. The method as claimed in claim 8, wherein step a) comprises:
 - detecting a first malfunction in the electric vehicle, the first malfunction immediately affecting other functions of the electric vehicle from being performed normally; and
 - detecting a second malfunction in the electric vehicle, the second malfunction allowing other functions of the electric vehicle to be performed normally;
 - wherein step b) comprises:
 - generating a corrected voltage by gradually decreasing the voltage which controls the speed when the second malfunction is detected;
 - wherein step c) comprises:
 - applying the corrected voltage to the electric motor (M) to control the speed when the second malfunction is detected; and
 - d) electrically braking the electric motor (M) when the first malfunction is detected.
12. The method as claimed in claim 11, further comprising the step of:
 - e) electrically braking when the corrected voltage is zero volts.

13. The method as claimed in claims 8 to 12, wherein the electrical braking is dynamic braking.

14. The method as claimed in claims 8 to 12, wherein the electrical braking is regenerative braking.

10

15

20

25

30

35

40

45

50

55

16

Fig. 3

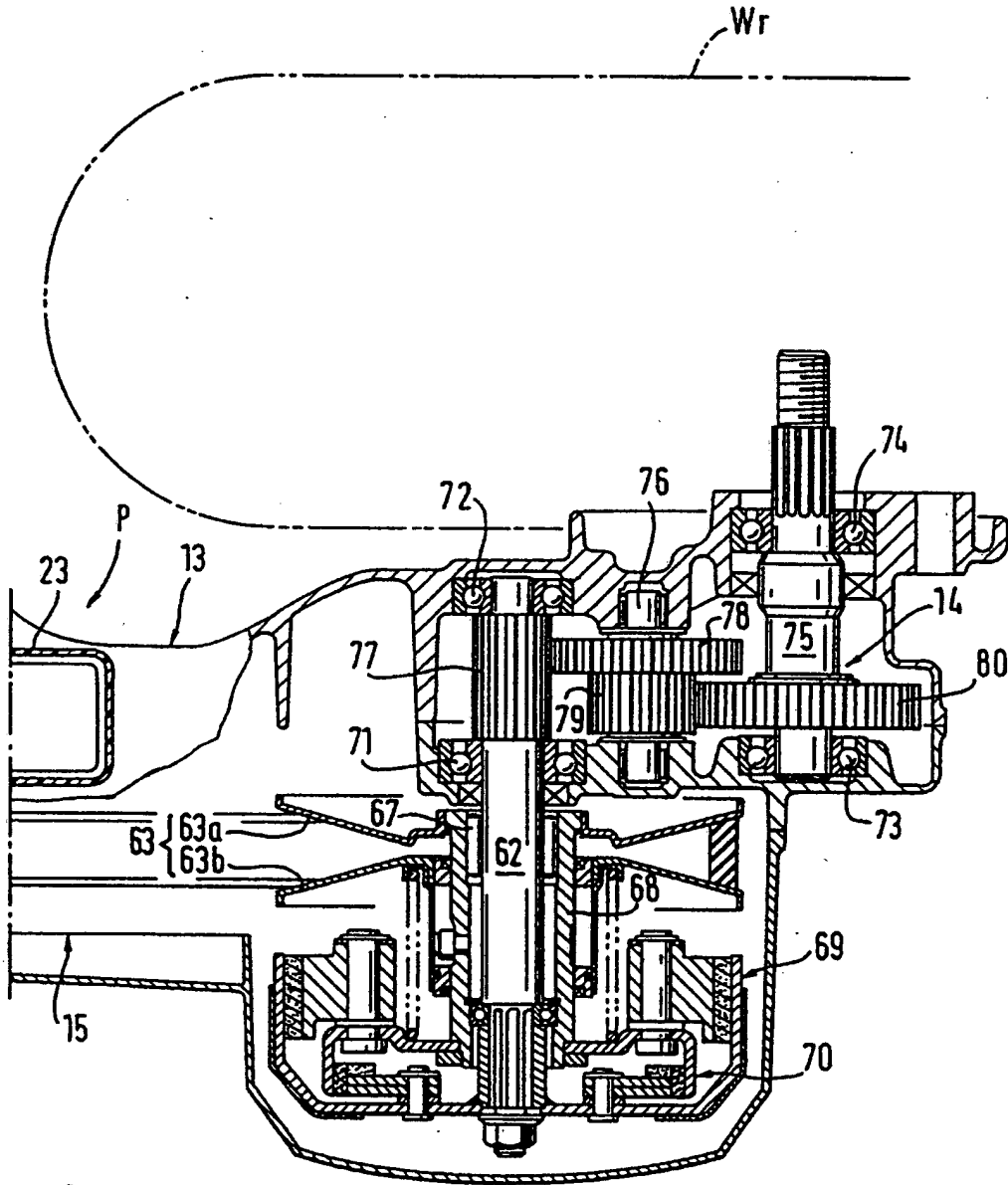

Fig. 4

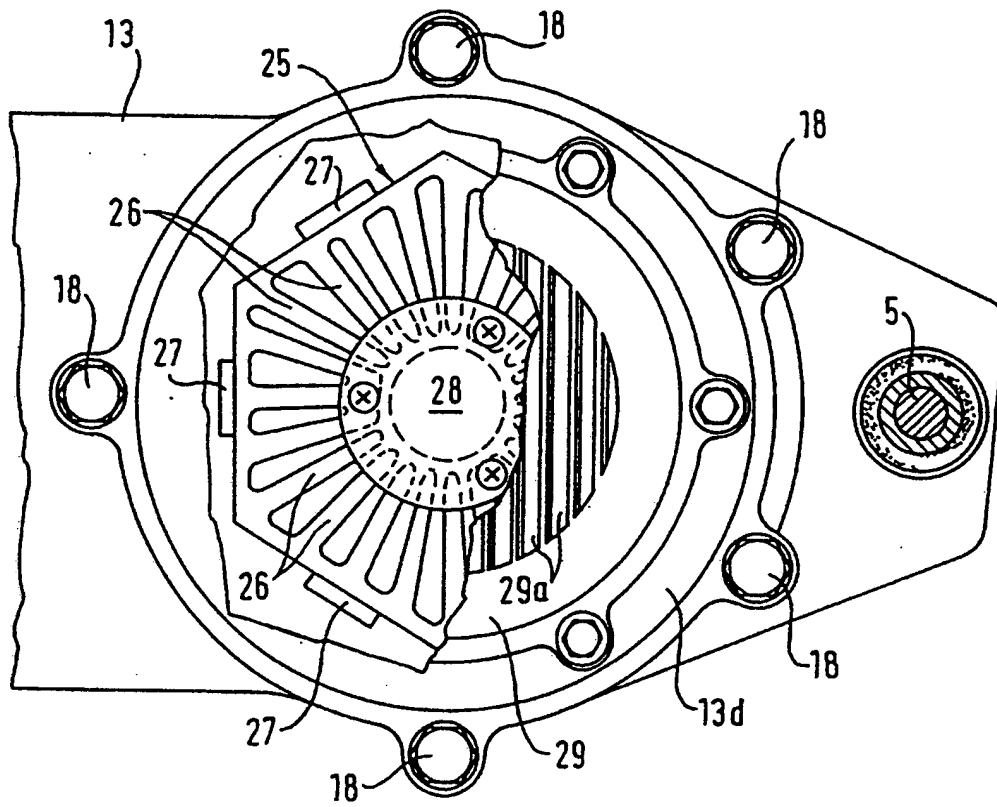

Fig. 20

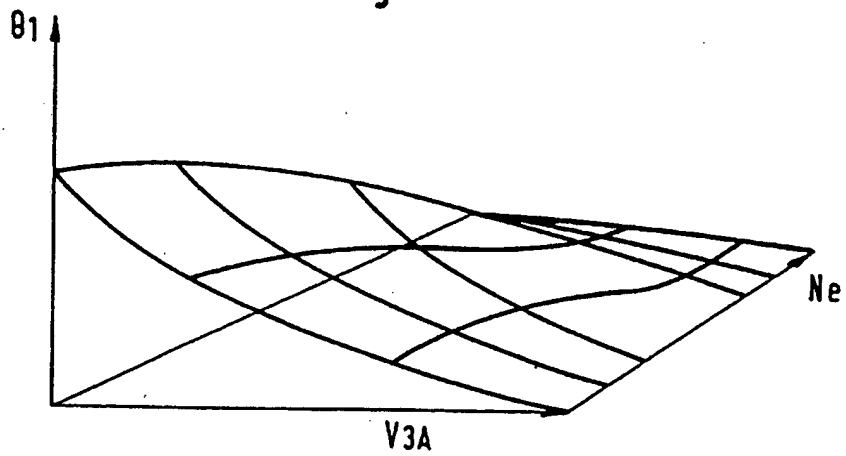

Fig. 5

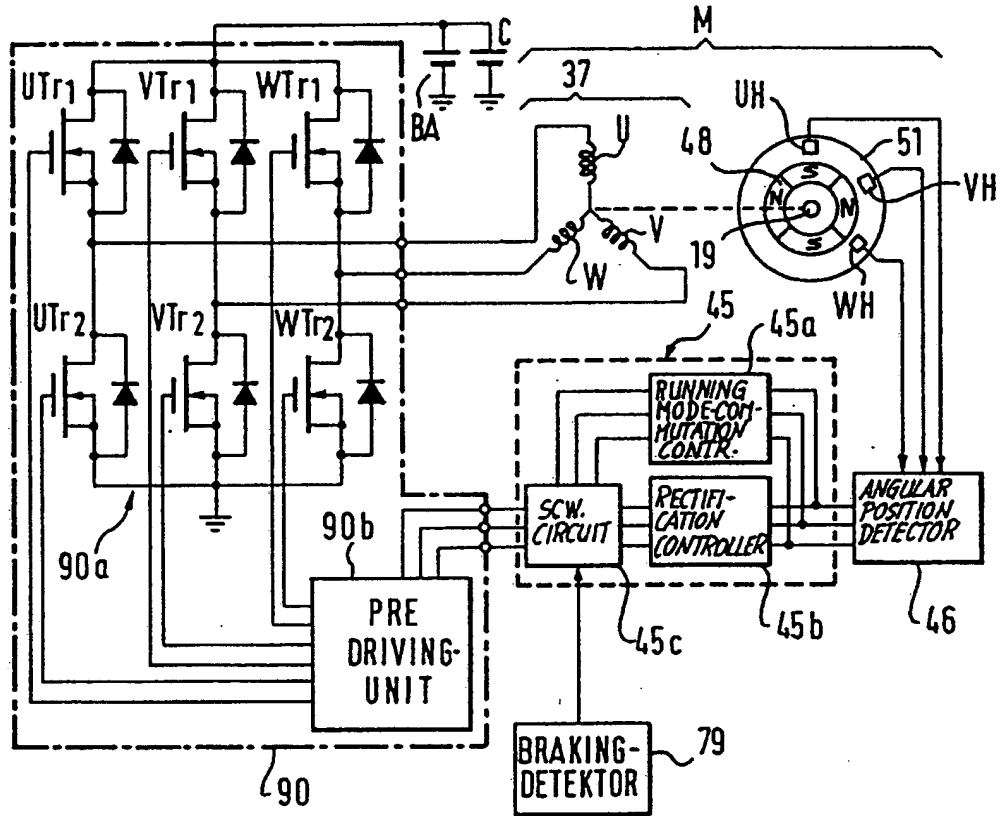

Fig. 24

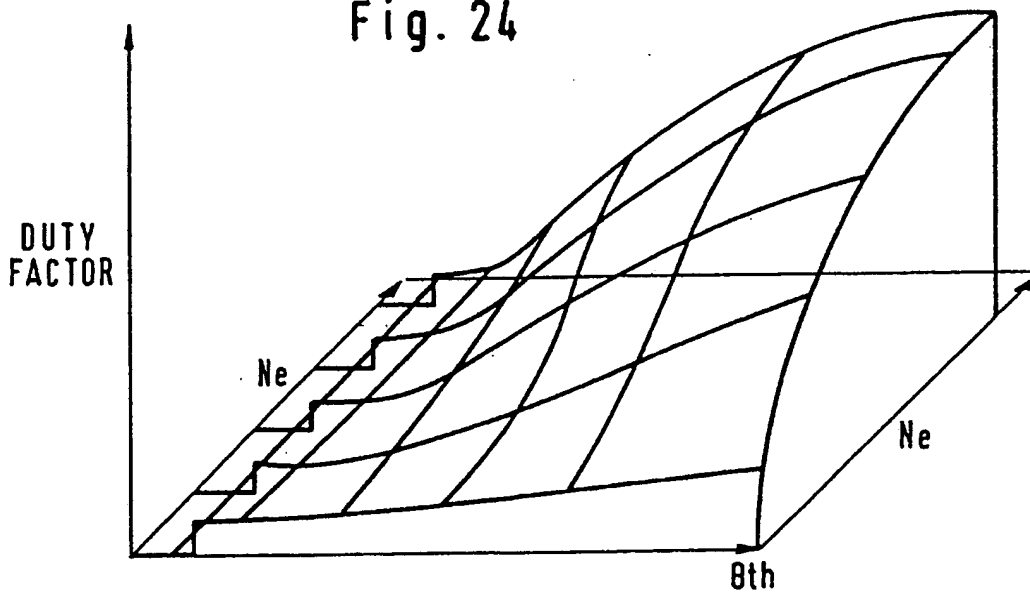

Fig. 6

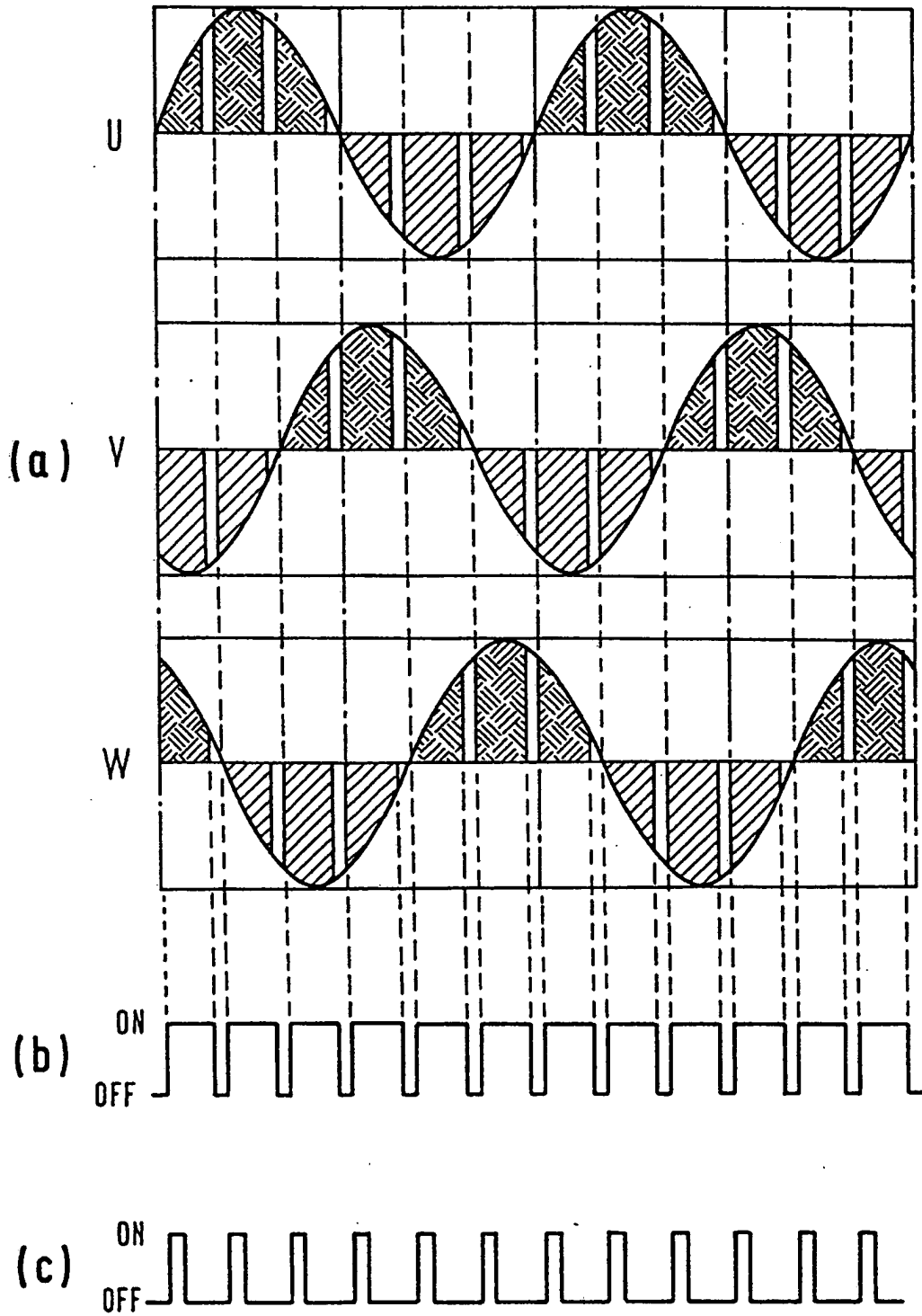

Fig. 7

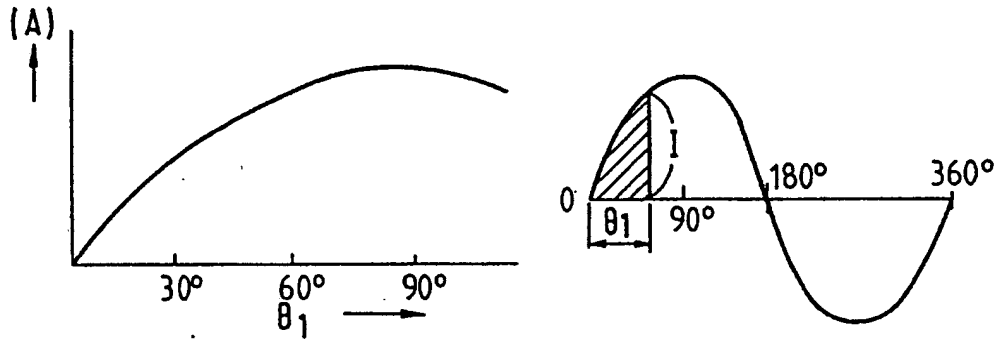

Fig. 8

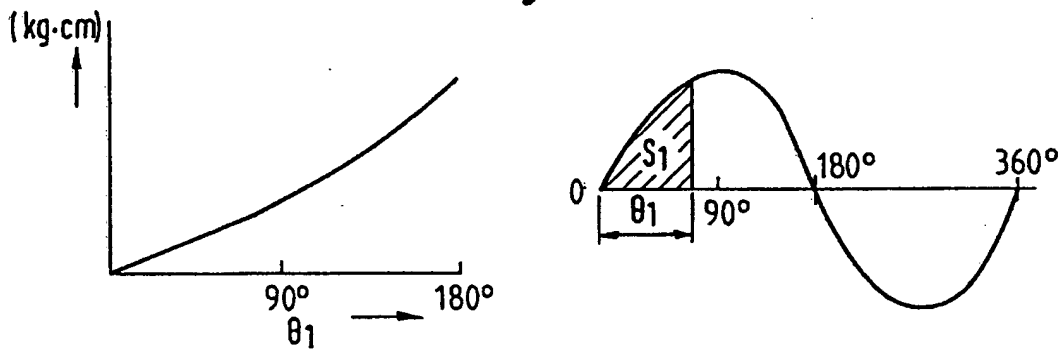

Fig. 9

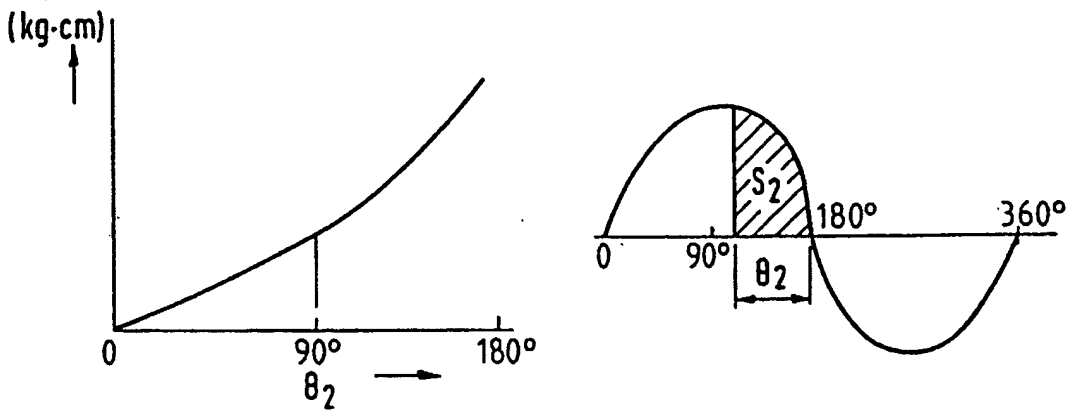

Fig. 10

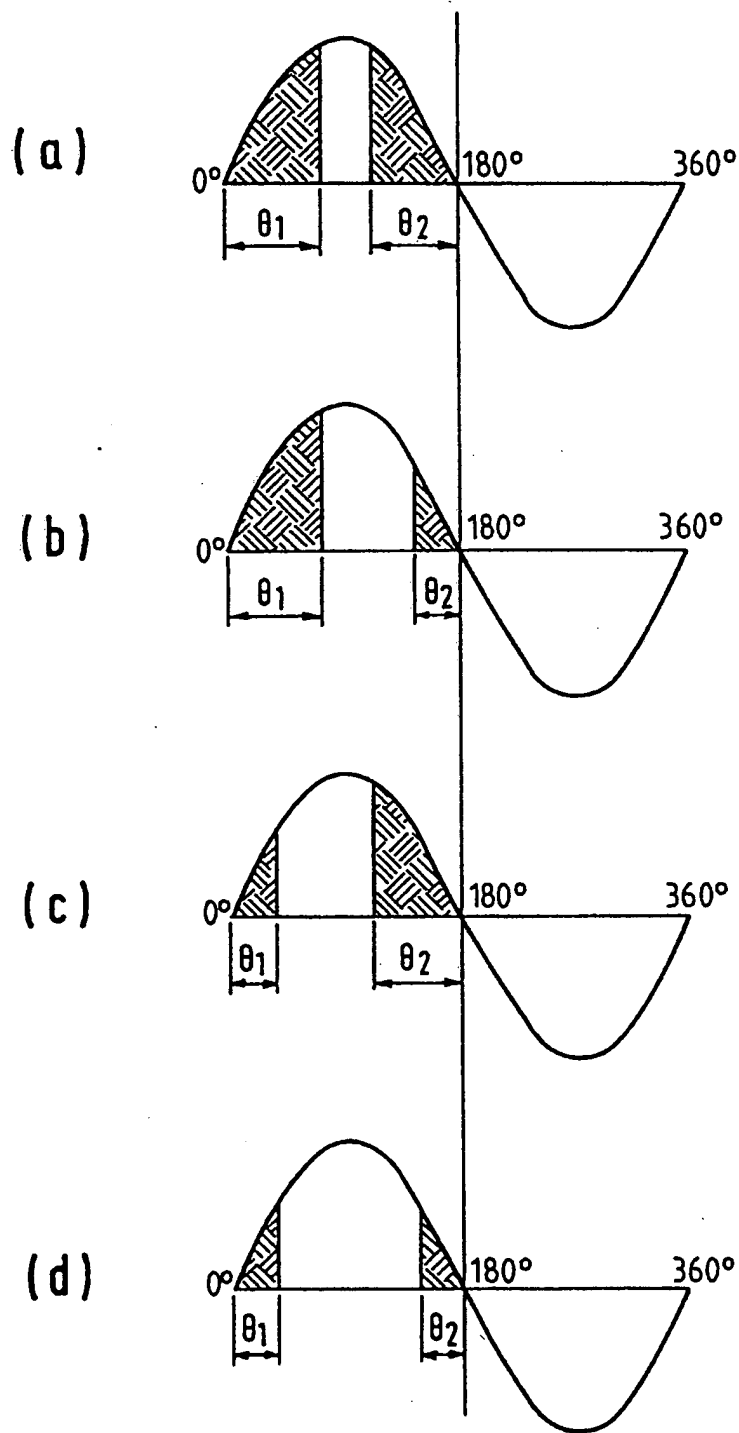

Fig. 11

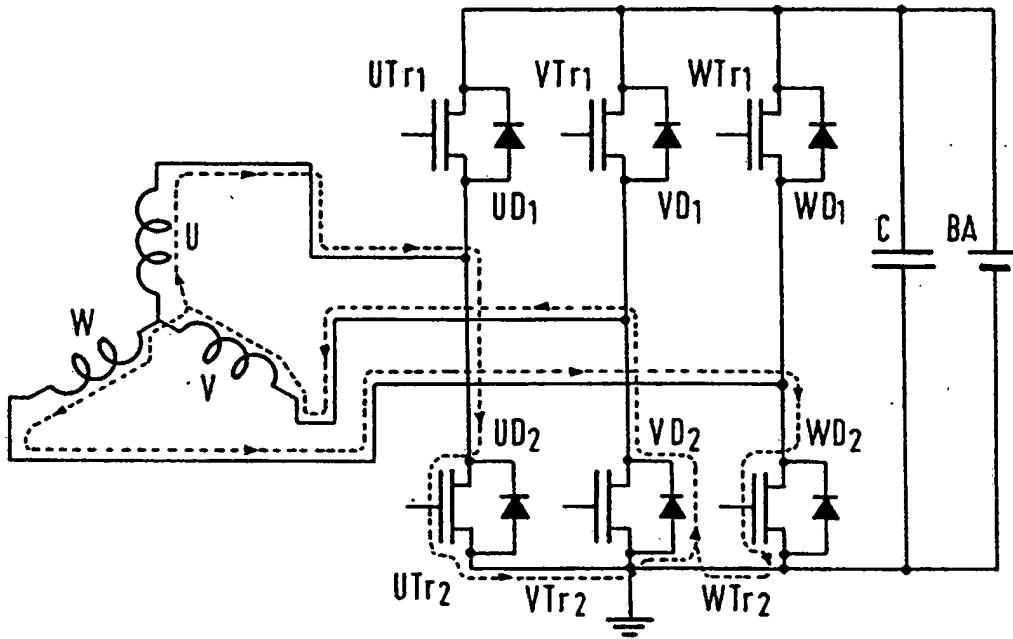

Fig. 12

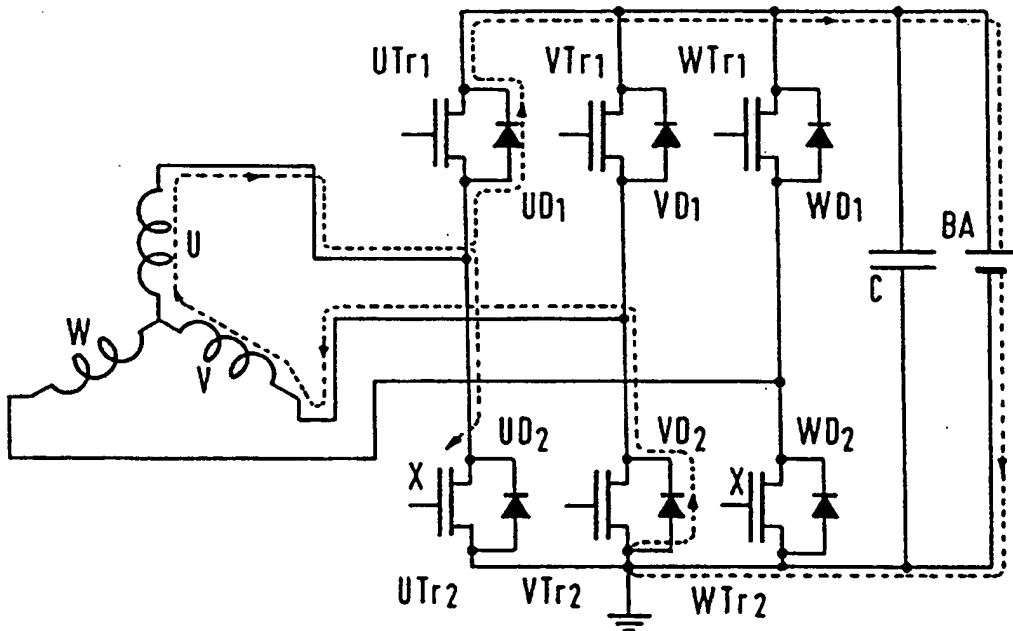

Fig. 13

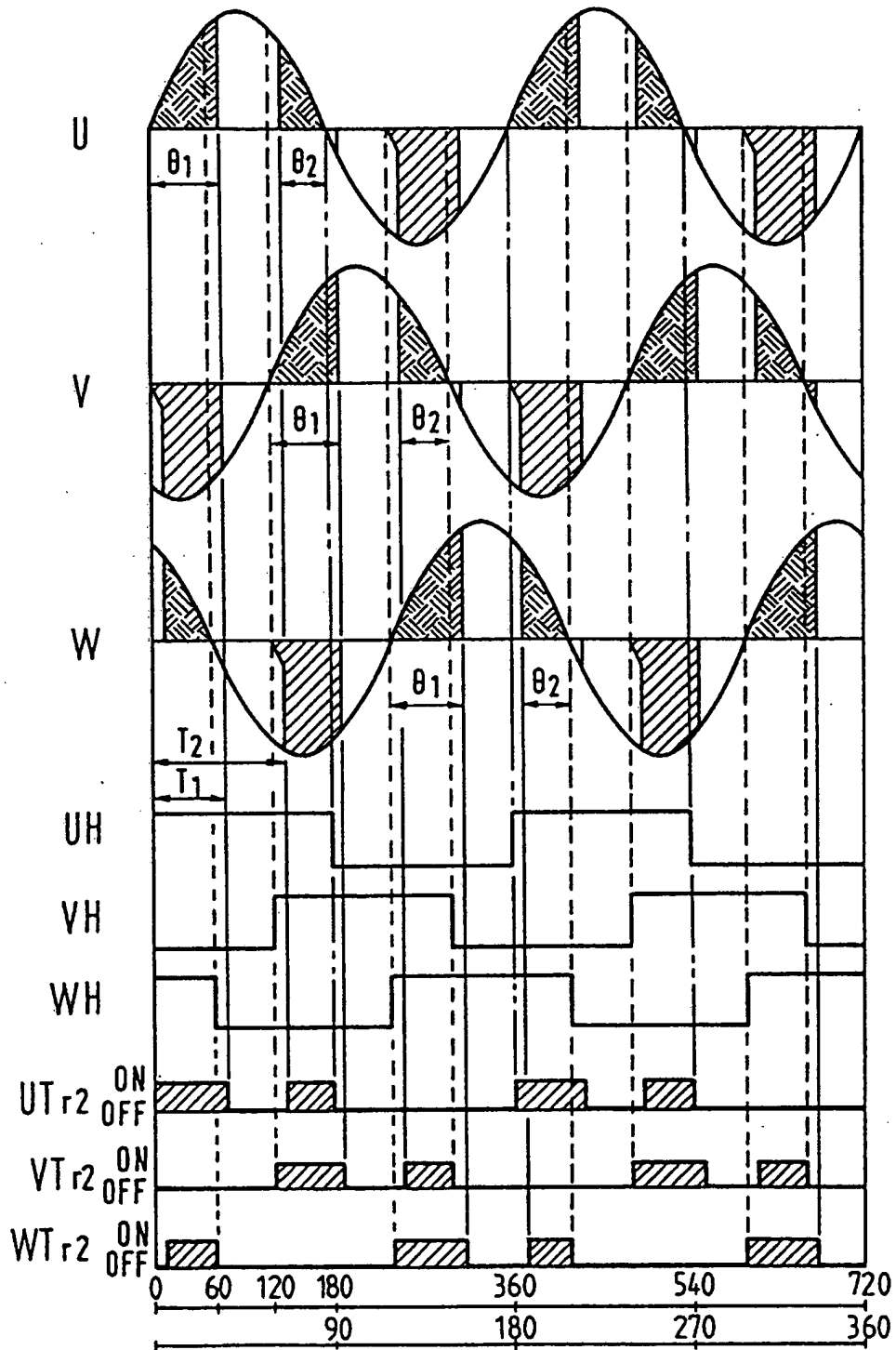

Fig. 14

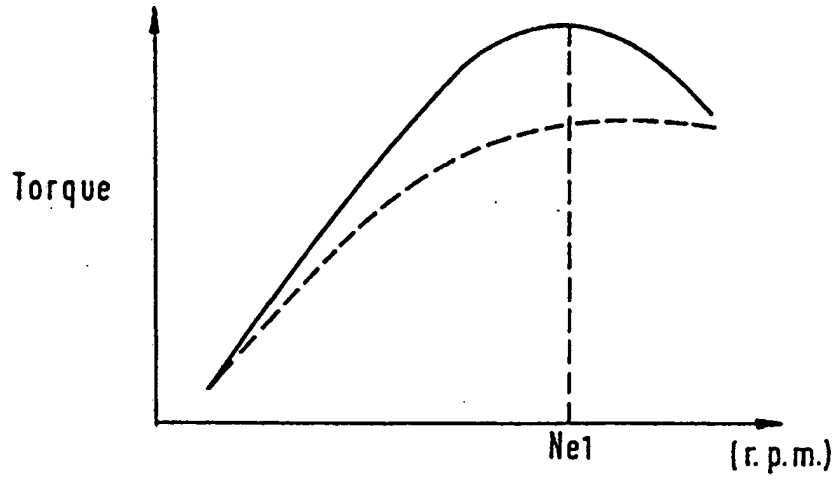

Fig. 15

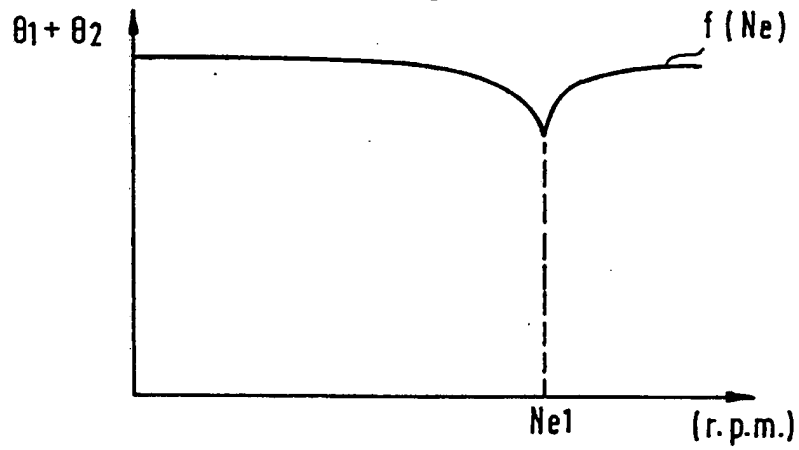

Fig. 16

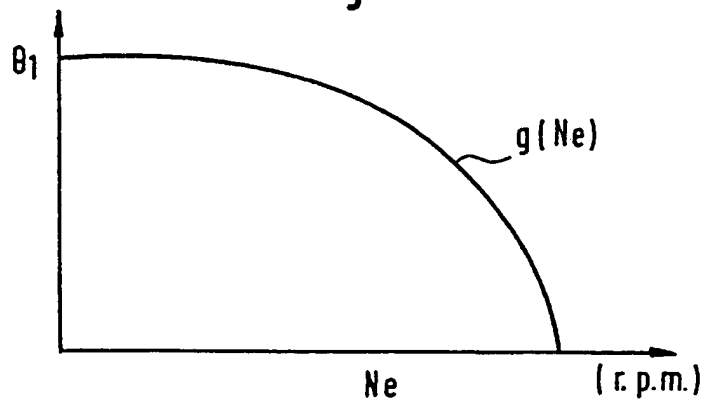

Fig.17

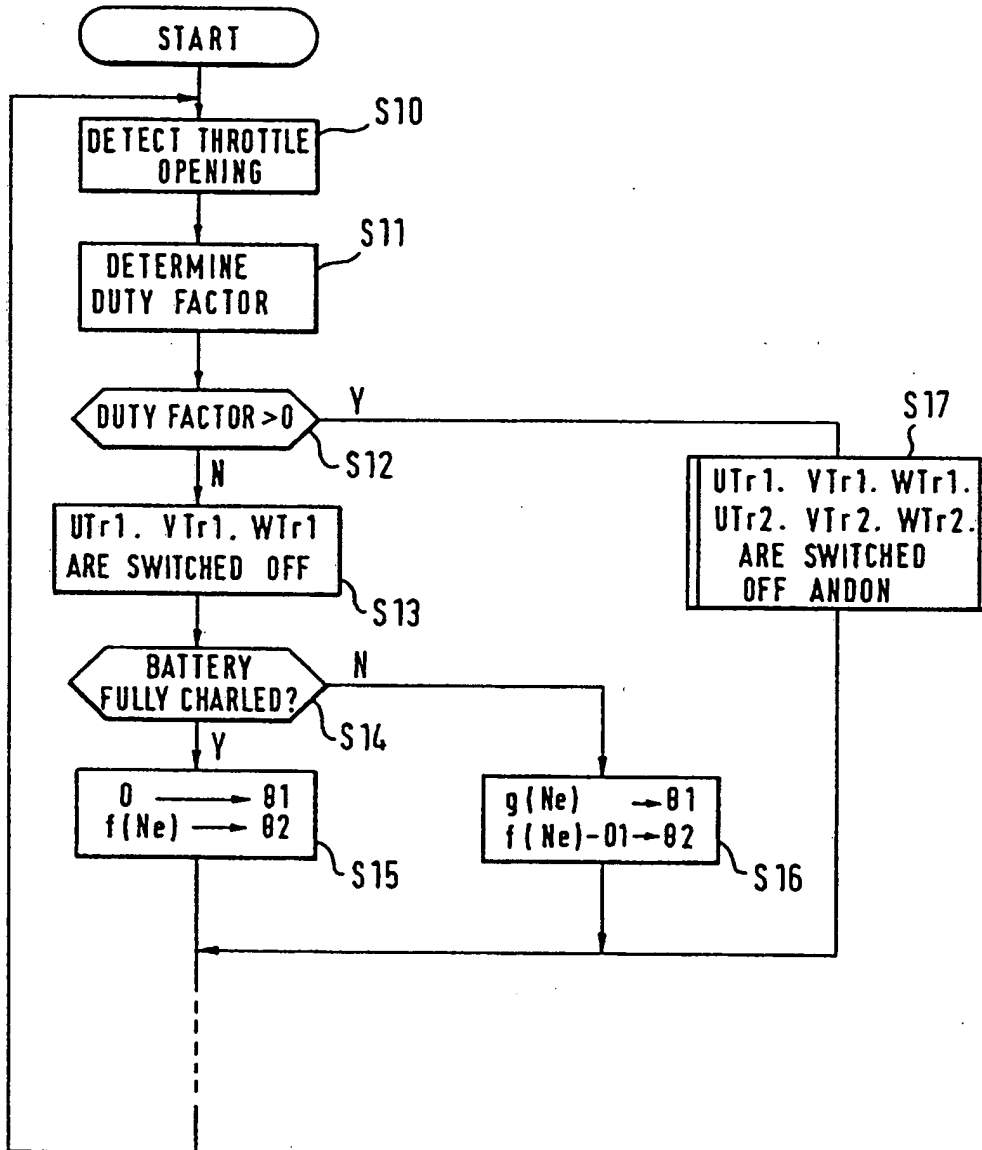

Fig.18

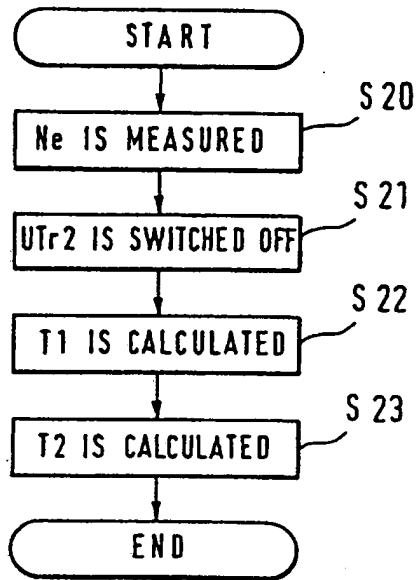

Fig.19

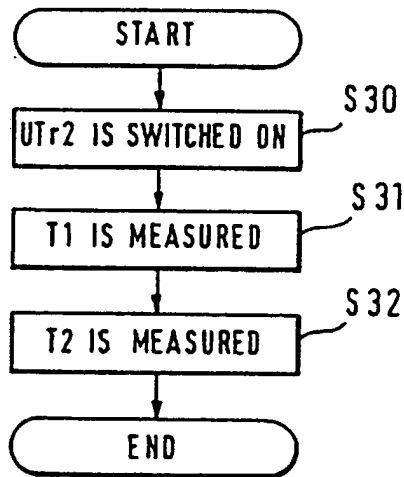

Fig. 21

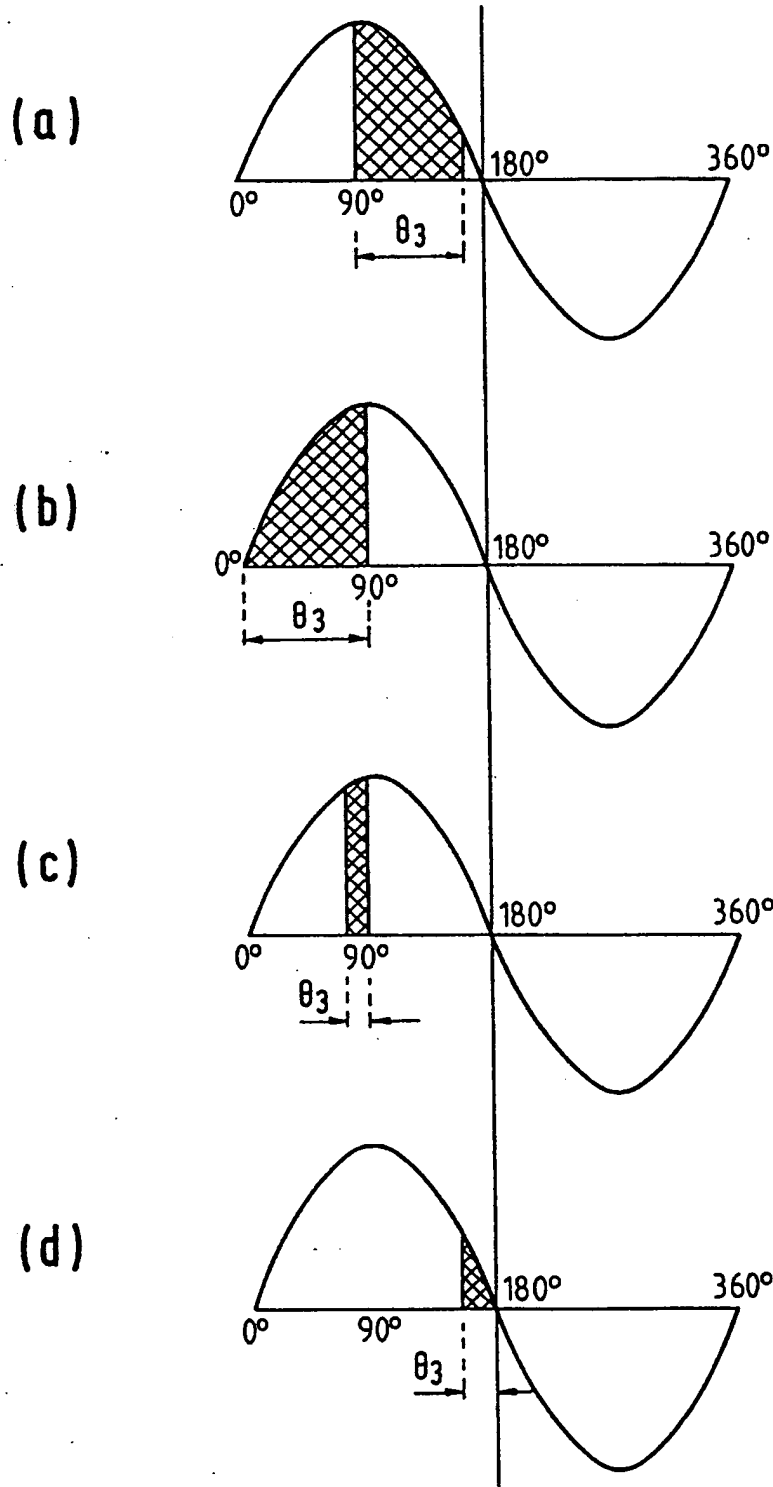

Fig. 22

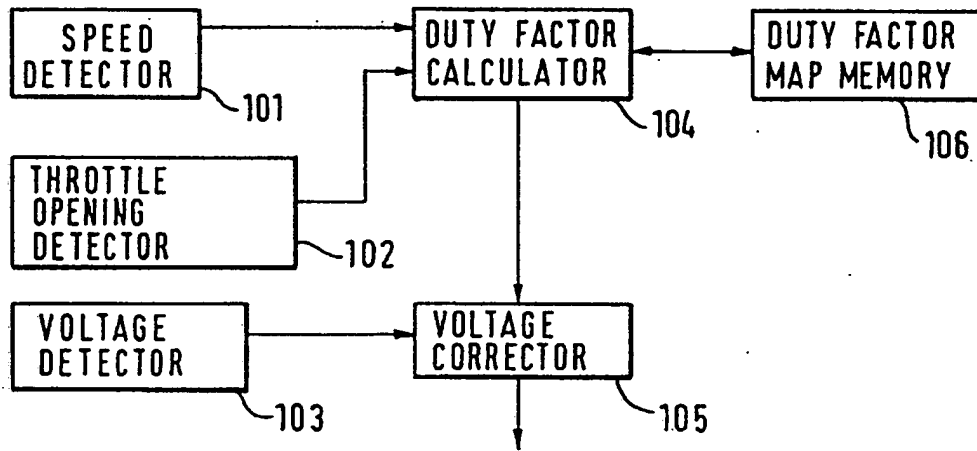

Fig. 23

θ_{th} \ N_e	N_{e0}	N_{e1}	N_{e2}	-----	N_{e15}
θ_{th0}	D(0.0)	D(0.1)	D(0.2)	-----	D(0.15)
θ_{th1}	D(1.0)	D(1.1)	D(1.2)		
θ_{th2}	D(2.0)				
⋮	⋮			D(X.Y)	
θ_{th15}	D(15.0)				D(15.15)

Fig. 25

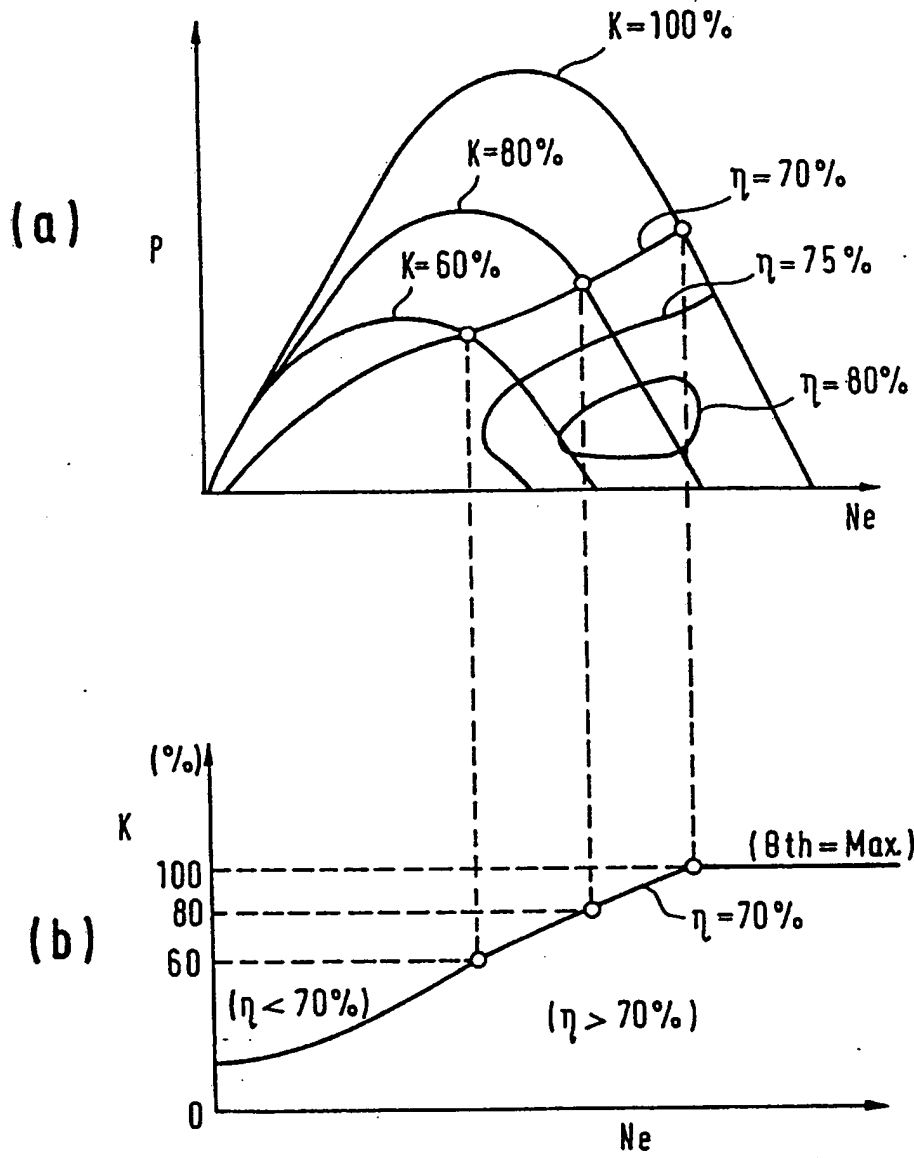

Fig. 26

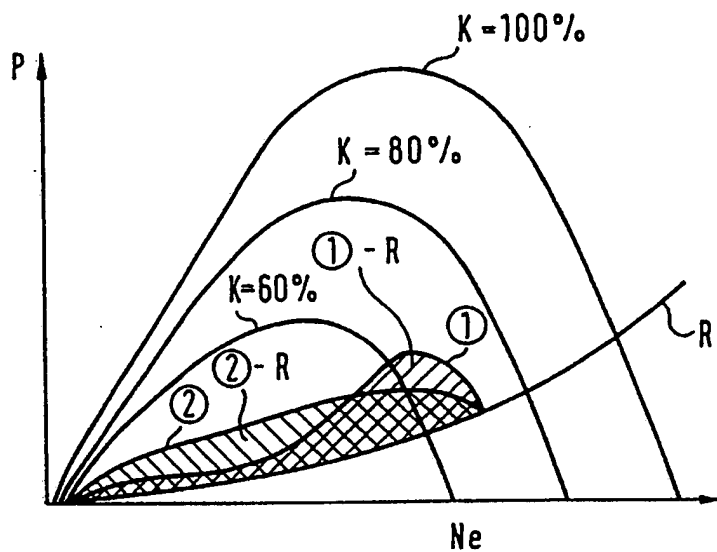

Fig. 27

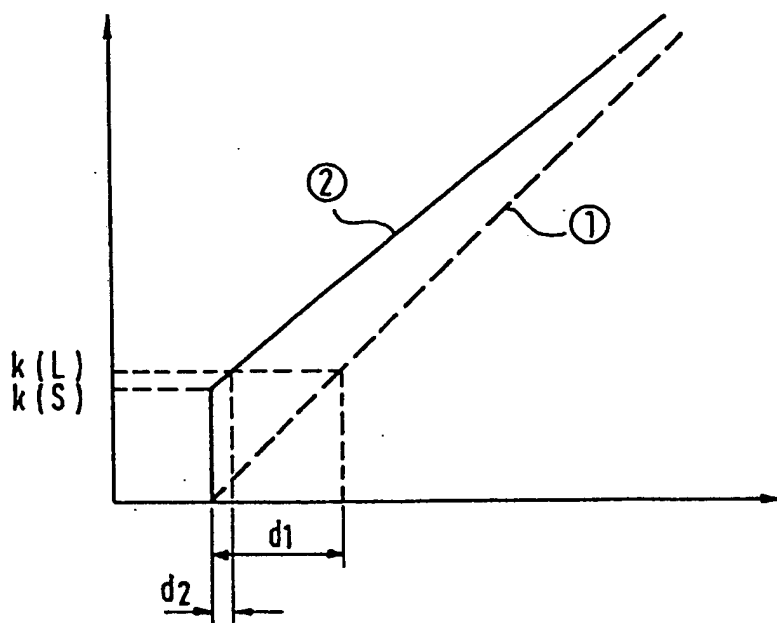

Fig. 28

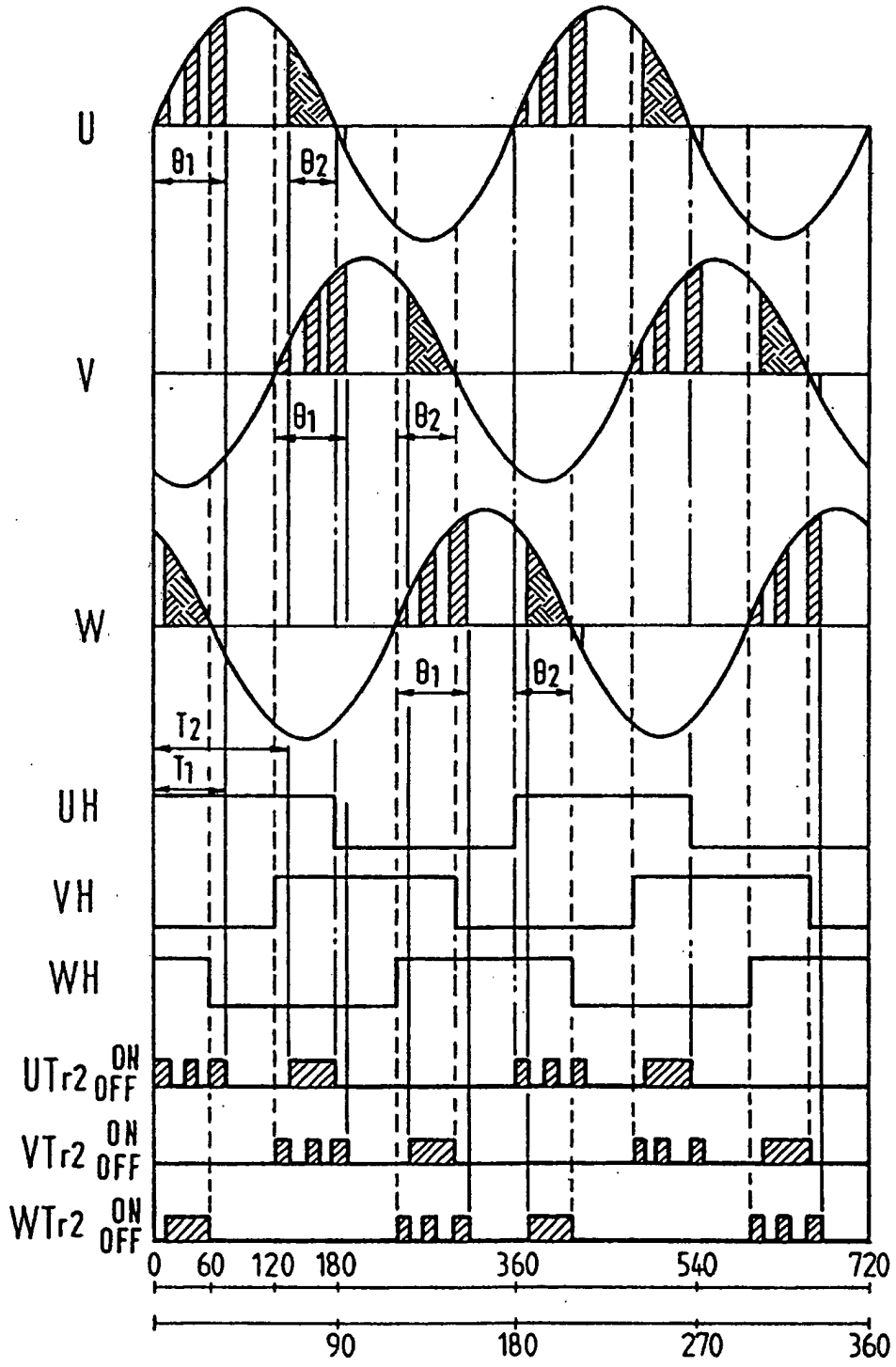

Fig. 29

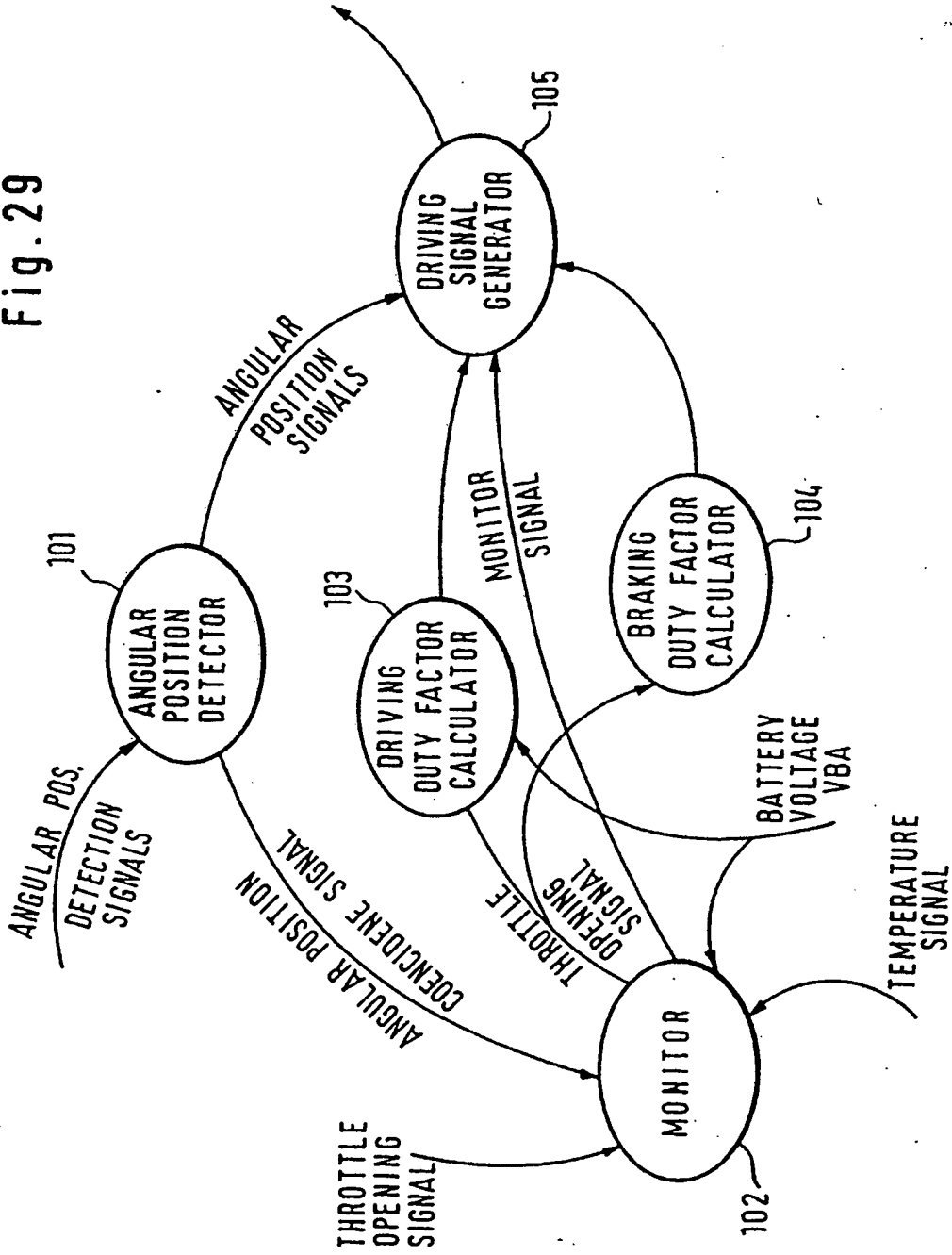

Fig. 30

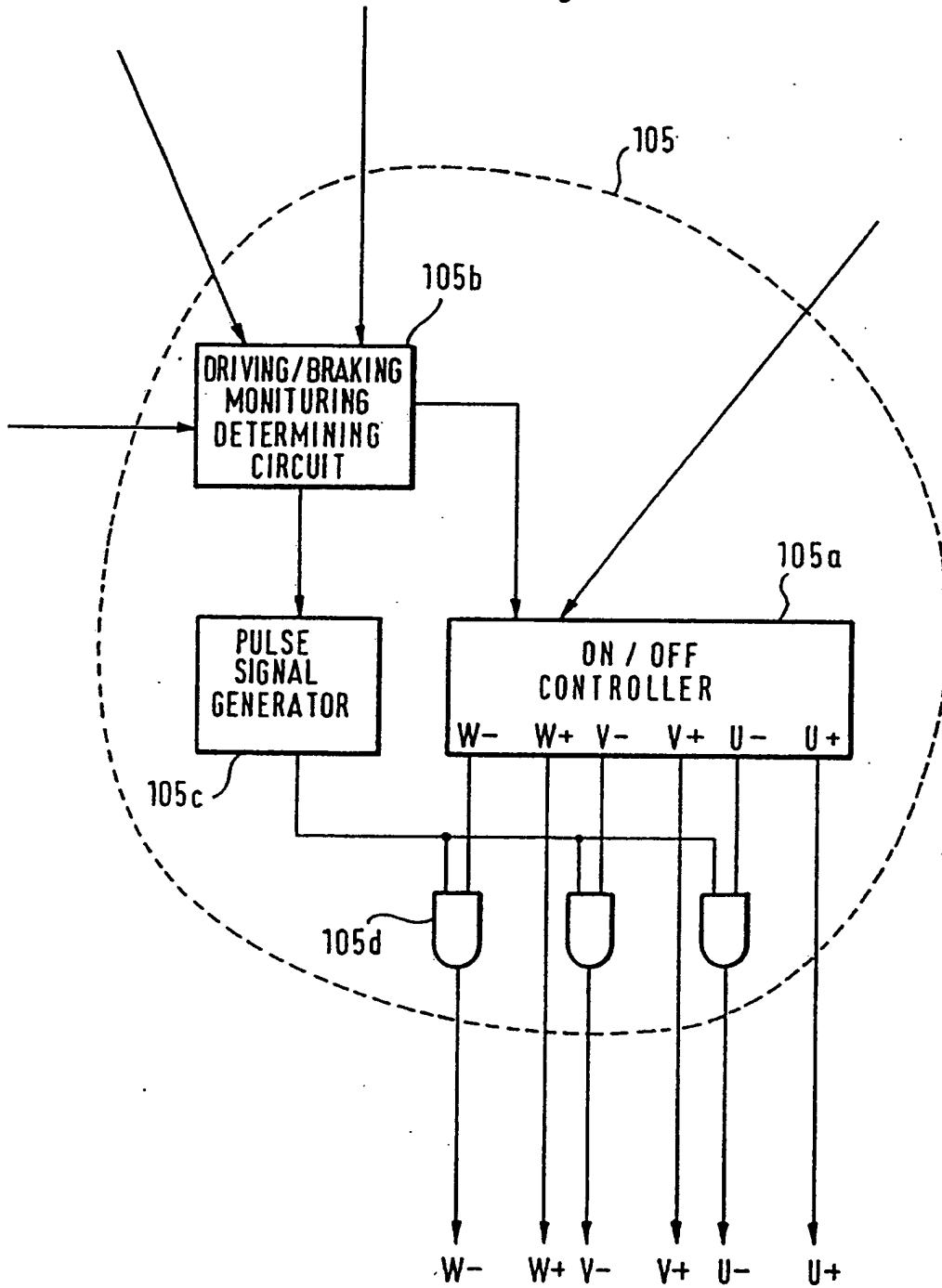

Fig. 31

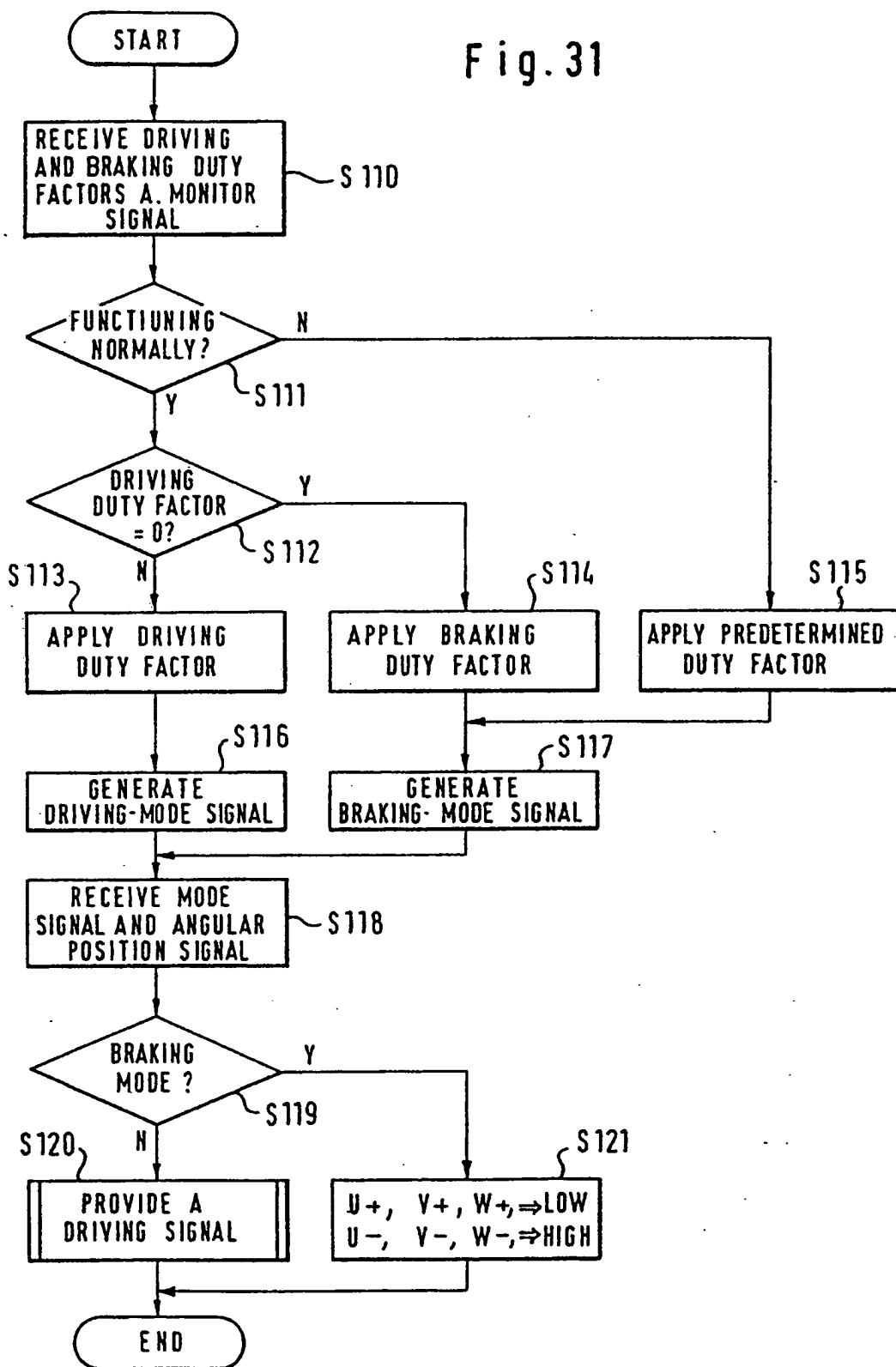

Fig. 32

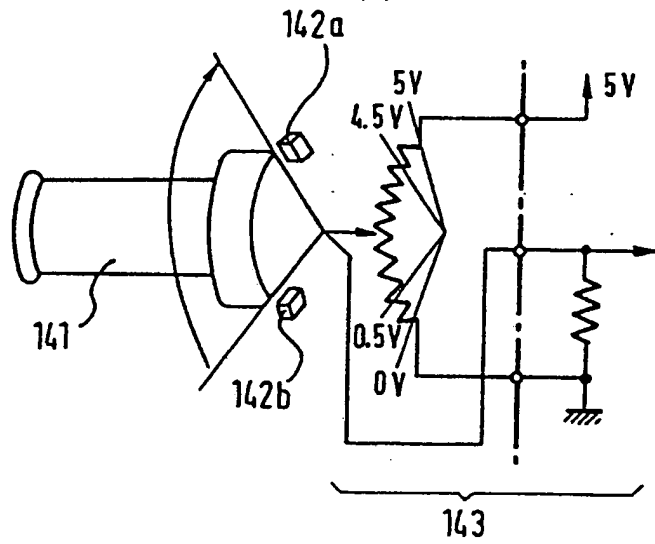

Fig. 33

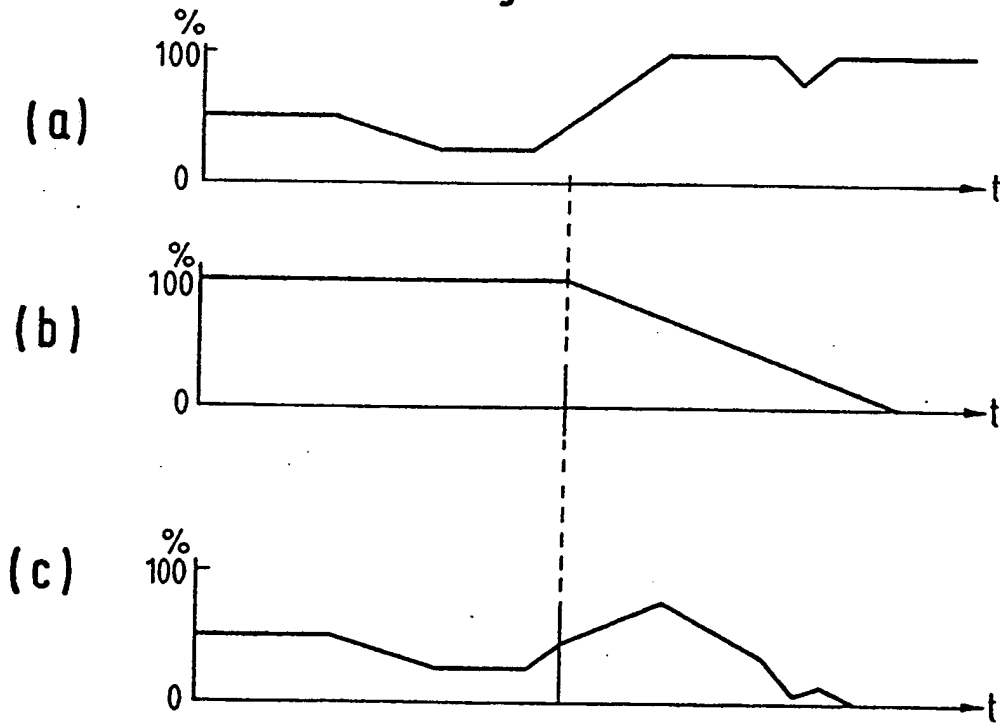

Fig. 34

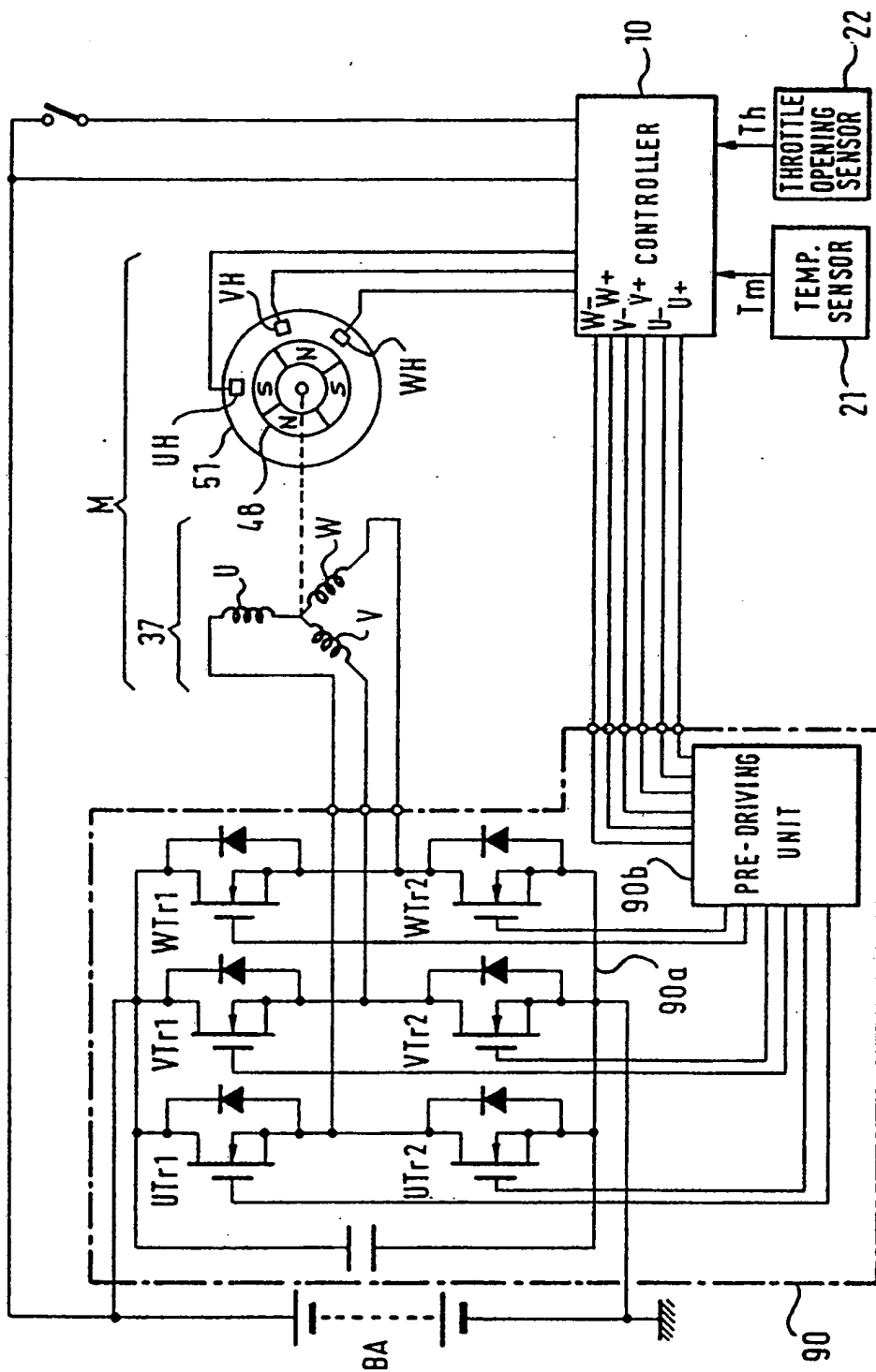

Fig. 35

UH	VH	WH	
N	S	N	# 0
N	S	S	# 1
N	N	S	# 2
S	N	S	# 3
S	N	N	# 4
S	S	N	# 5

Fig. 36

	SENSOR POSITIONS	DRIVING MODE						—
		# 0	# 1	# 2	# 3	# 4	# 5	
	U +	ON	ON	OFF	OFF	OFF	OFF	OFF
	U -	OFF	OFF	OFF	ON	ON	OFF	ON
	V +	OFF	OFF	ON	ON	OFF	OFF	OFF
	V -	ON	OFF	OFF	OFF	OFF	ON	ON
	W +	OFF	OFF	OFF	OFF	ON	ON	OFF
	W -	OFF	ON	ON	OFF	OFF	OFF	ON

Fig. 37

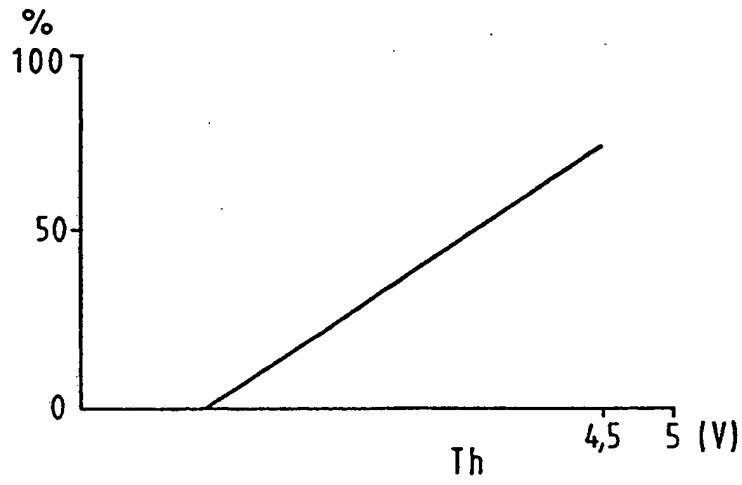
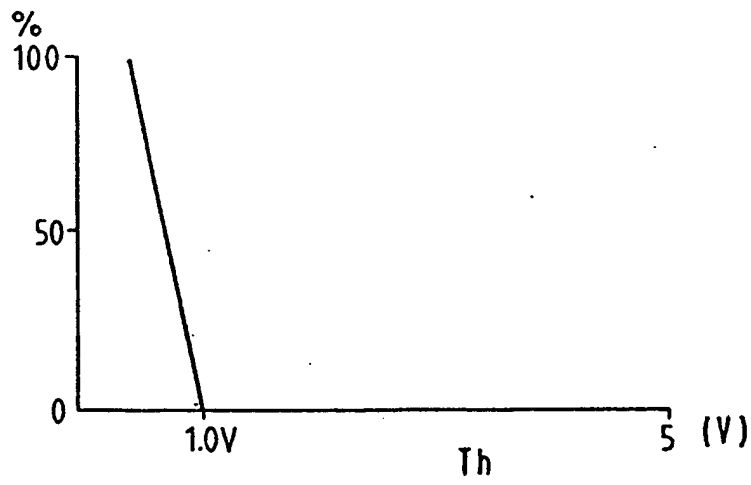

Fig. 38





European Patent
Office

EUROPEAN SEARCH REPORT

Application Number
EP 95 10 4980

DOCUMENTS CONSIDERED TO BE RELEVANT			
Category	Citation of document with indication, where appropriate, of relevant passages	Relevant to claim	CLASSIFICATION OF THE APPLICATION (Int. CL.5)
A	US-A-4 544 868 (MURTY V BALARAMA) 1 October 1985 * abstract; figure 1 * ---	1,4,8	B60L7/10 B60L3/10 B60L3/00
A	US-A-4 401 926 (MORTON JOHN ET AL) 30 August 1983 * abstract; figure 1 * ---	1,4,8	
A	GB-A-2 159 011 (GEN ELECTRIC) 20 November 1985 * abstract; figure 6 * ---	1,4,8	
A	GB-A-2 201 309 (CABLEFORM LTD) 24 August 1988 * abstract; figure 1 * ---	1,4,8	
A	EP-A-0 311 355 (CHLORIDE GROUP PLC) 12 April 1989 * abstract; figure 1 * ---	1,2,8	
X	GB-A-2 182 217 (MITSUBISHI DENKI K.K.) * abstract; figure 2 * -----	1,2,8,9	TECHNICAL FIELDS SEARCHED (Int. CL.5) B60L H02P
The present search report has been drawn up for all claims			
Place of search THE HAGUE		Date of completion of the search 23 May 1995	Examiner Beyer, F
CATEGORY OF CITED DOCUMENTS X : particularly relevant if taken alone Y : particularly relevant if combined with another document of the same category A : technological background O : non-written disclosure P : intermediate document		T : theory or principle underlying the invention E : earlier patent document, but published on, or after the filing date D : document cited in the application L : document cited for other reasons ----- & : member of the same patent family, corresponding document	

EPO FORM 1503 (01.92) (FR/EN)